

Farm Equipment

For Sale - J.D. level bed, 2 row potato digger; 16 ft. wagon bed; posts and logs from a barn. Ph: 717-898-7797.

For Sale - John Deere 4020 Diesel, WFE, Power shift, weights, cab, 18.4x38 rear, 10.00x16 front. Original Paint. 717-548-3402

Farm Equipment

For Sale - John Deere 730 diesel: 1770 hours: 3-bottom plow. Call 717-235-2572 before 3 p.m. or 717-235-4188 after 7 p.m. or Saturdays.

New Holland No. 516 manure spreader, 205 bu.; good condition. Michael A. Palmer, RD 3 Bangor, PA 18013; 215-258-3377

For Sale - Case, 530 Diesel Backhoe and Loader, 4 spd. shuttle shift, High & Low Range
Dump Truck - 67 Dodge w-cab shield, 4 spd w-2 spd. Rear - 318 Engine.
Trailer - 15 Ton Martin, Elec. Brakes, Side load w-ramps.
Will sell all above for \$13,500.00
Thomas H. McDowell, RD 1, Stewartstown, Pa. 17363 717-382-4174

Melrose 600 Bobcat Skid Loader \$2975.00;
International 2200 B Skid Loader \$2975.00;
John Deere 24 Skid Loader 1973 \$3575.00;
1000 Mueller Tank \$2575.00;
500 Gallon Unico with Compressor \$975.00.
Finance.
814-793-2829
CURRY SUPPLY
Curryville, Penna.

Farm Equipment

For Sale - John Deere 95 combine w-13 ft. Grain head, Model 435, 4-row 40" Corn head, \$9,500 or best offer; Moridge Grain Dryer, 400 bu. capacity, 1 1/2 yrs. old; Farmhand Blurr Mill Grinder. Phone: 609-737-2375

Farm Equipment

Model 82 Massey Harris Combine.
New Idea 208 Spreader
A.C. D19 Diesel Tractor
N.I. 702 Gas Un-Tractor
ROY H. BUCH, INC.
Ephrata
717-859-2441

GO **BIG RED**

WINTER CLEARANCE SALE OF MANURE SPREADERS

Bear claw paddles assure fine shredding, even spreading



SAVE

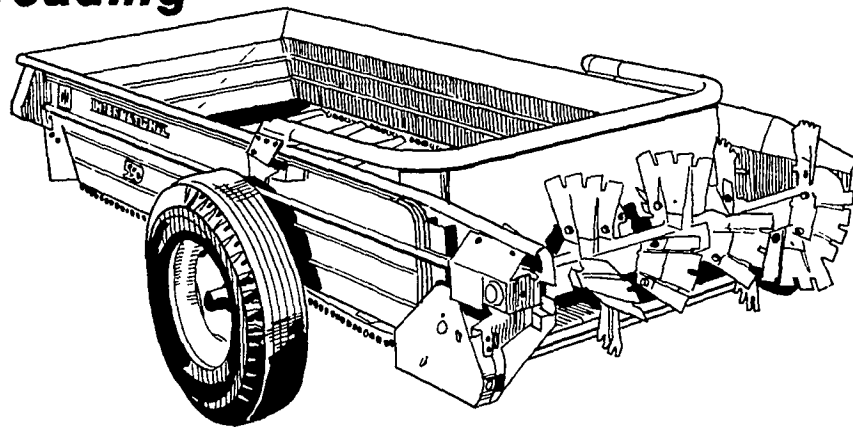

International 500 Series Spreaders

You're sure to find the spreader you need in this big International line-up of 6 high-performance models. The single-beater unit has high-strength spring-steel paddles with staggered cutting "bear claws" to tear and shred packed and frozen chunks thoroughly, then spread material into the pattern you prefer. Extremely simple, yet highly effective.

- Sizes from 148 to 313 cu. ft. capacities (rated heaped boxes).

- A-frames extend back to wheels, prevent box twisting and jerking
- Corrosion-resistant steel box sides on 4 smaller models guaranteed for the life of the spreader.
- High-quality, high-strength pintle chain used on aprons.
- Slurry pans and hydraulic endgates available for liquid-type manures
- Optional upper beaters and upper spring bars boost spreading efficiency.

SAVE

THESE DEALERS WILL OFFER HIGH TRADE-IN VALUE AND LOW DISCOUNT PRICES FOR THIS CLEARANCE SALE DURING JANUARY & FEBRUARY.

SEE US FOR DETAILS. EASY FINANCE PLANS AVAILABLE.

C & W EQUIPMENT, INC.

260 York Rd Carlisle, PA 17013
717-243-4419

R. S. HOLLINGER & SON

Mountville
717-285-4538

C. B. HOOBER & SON

Intercourse
717-786-8231

MESSICK FARM EQUIP.

Elizabethtown
717-367-1319

LAMB'S FARM MACHINERY

Thorndale, Pa.
215-269-2676

CAMPBELL SALES & SERVICE, INC.

McAlisterville, PA
717-463-2191

PERRONE EQUIPMENT CORP.

101 Rosehill Ave.
West Grove, PA
215-869-2474

HERITAGE INTERNATIONAL, INC.

1054 S. State St
Ephrata, PA
717-733-2283

CLARENCE WILSON & SONS

Kemerton
215-933-3581

COPE & WEAVER CO.

New Providence
717-786-7351

BIGGS INCORPORATED

34 Buckley Ave.
Rising Sun, MD
301-658-5531

ERB & HENRY EQUIP. INC.

22-26 Henry Ave., New Berlinville, PA
1 Mile North of Boyertown
215-367-2169

L. L. ECKROTH FARM EQUIP., INC.

RD 2 New Ringgold, PA
717-943 2367

SCHOENECK INTERNATIONAL

Oakwood Lane at Rt. 873
Near Neffs [Schnecksville, Pa.]
215-767-3806 or 437-4813

SWOPE & BASHORE, INC.

Myerstown RD1 [Frysstown]
717-933-4138

