



Jeff Rexroth of Red Lion FFA took the reserve senior champion Jersey honors at the South Central District Dairy Show held at the South Mountain Fairground, recently.

Red Lion FFA takes honors

RED LION - The Future Farmers of America from the Red Lion Area Chapter won several awards at the South Central District Dairy Show held at the South Mountain Fairgrounds, recently.

Members came home with grand champion and reserve champion Jersey. They also won grand champion Brown Swiss and Guernsey.

York County took first place Jersey and Holstein with their county groups of four.

The type conformation

results which were judged using the modified Danish System of blue, red and white merit were: Brown Swiss - Tina Taylor, grand champion and junior champion; Guernsey Breed - Doug Killgore, grand champion; Jersey - Barb Snyder, grand champion and junior champion, Lori Wolford, reserve junior champion, and Jeff Rexroth, reserve senior champion; Holsteins - Glenn Crowl, junior champion.

In showmanship, Leon Crowl won the trophy for champion showman.



The grand champion hog of the Berks County 4-H Market Swine Sale was a Duroc cross which was owned by Allan S. Rohrbach, Shoemakersville. Pictured with 13-year-old Allan and his animal is Jerry L. Clemens, buyer for Hatfield Packing Company, who purchased the animal.

Rohrbach has champion hog

LEESPORT - Allan S. Rohrbach, Shoemakersville R1, owned the grand champion hog sold recently at the Berks County 4-H Market Swine Sale held at the Leesport Market and Auction, here.

The Duroc-Crossbred sold for \$1.75 a pound, weighed 240 pounds brought a total of \$420. The animal was purchased by Hatfield Packing Company, Hatfield. Rohrbach belongs to the Virginville 4-H Dairy and Swine Club and is the 13-year-old son of Mr. and Mrs. A. S. Rohrbach.

The reserve grand champion was also owned by Rohrbach, and was another Duroc-Crossbred. This animal weighed 260 pounds and sold for 75 cents a pound. Its total value was \$195, and was purchased by Hatfield Packing Company.

In total, there were 18 4-H members participating in the sale with 30 animals sold. The total weight of the animals was 6,360 pounds and the average weight was

212 pounds. The average price for the sale, without the champions, was 53 cents a pound.

Other buyers of the 4-H animals were: Ralph W. Zettlemoyer Auction Co., Ben Martin, livestock dealer, Kenneth E. Miller, James Hughes, Shirley's Lunch Counter, Yoder's Meat Market, Dan Good, Livestock Dealer, Lynn Schwalm, Leesport Market & Auction, and Clark's Packing Company.

Recipe

Savory Pork - Stuffed Peppers

- 1½ pounds ground pork
- 1 teaspoon salt
- ½ teaspoon pepper
- 1 can (10½ ounces) cream of celery soup
- 1 can (7 ounces) whole kernel corn, drained
- 1 medium onion, finely chopped
- 3 large green peppers
- 6 tomato slices, cut ¼ inch thick

Salt

Parmesan cheese

Lightly brown ground pork in large frying-pan; pour off drippings. Sprinkle salt and pepper over meat. Add celery soup, corn, and onion and cook slowly 10 to 12 minutes, stirring occasionally. Cut green peppers in half lengthwise and remove membrane and seeds; cook in boiling salted water for 2 minutes; invert and drain thoroughly. Fill pepper halves with meat mixture and place on rack in roasting pan. Bake in a moderate oven (350 degrees F.) for 15 minutes. Sprinkle salt on both sides of tomato slices and place on top of stuffed peppers. Sprinkle with Parmesan cheese and bake 15 minutes longer. (servings.

Great Ideas for Ground Por

We're slashin' prices

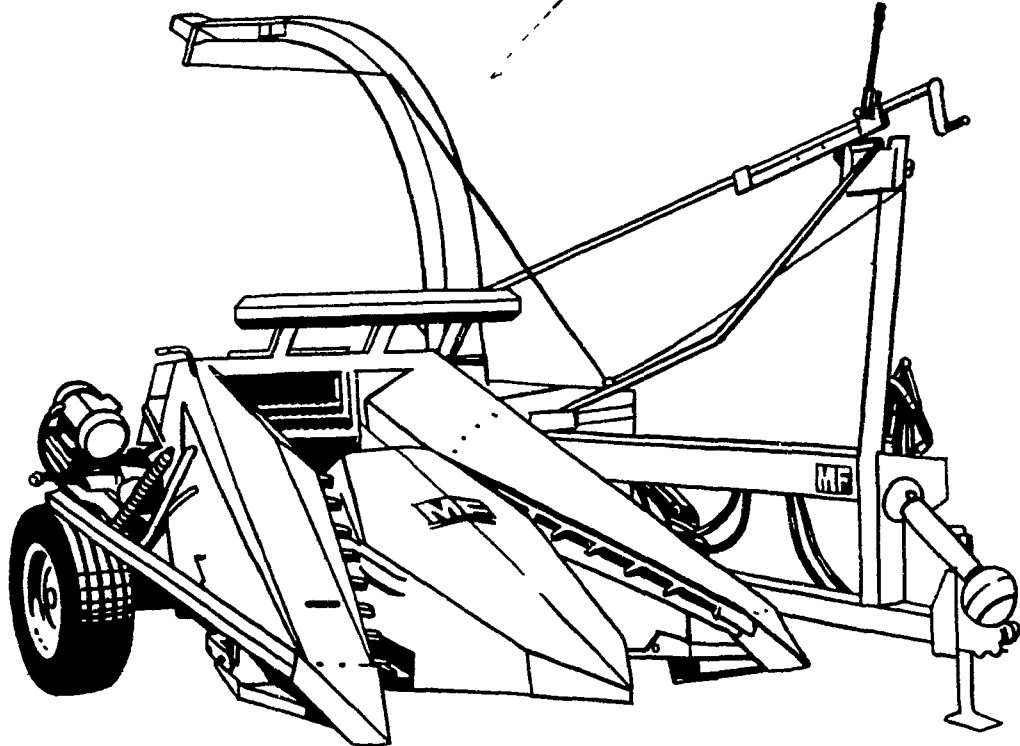

on MF forage harvesters

built for high capacity

chopping...

whatever the crop!

Model

MF 260
(26" wide
cutterhead)

MF 200
(20" wide
cutterhead)

PERFORMANCE PLUS

SAVE \$\$\$
if you buy NOW

S. G. LEWIS AND SON

West Grove, PA
[215] 869-9440
869-2214

LEBANON VALLEY IMPLEMENT CO.

700 E. Linden St.
Richland, PA
Phone: [717] 866-7518

MARLIN W. SCHREFFLER

Pitman PA
[717] 648-1120

A. L. HERR & BRO.

312 Park Ave
Quarryville PA
Ph: [717] 876-3521

M. M. WEAVER & SONS

North Groffdale Road
Leola, PA 17540
Phone: [717] 656-2321

NISSLEY FARM SERVICE

Charlestown Rd
Prospect Rd
Washington Boro, PA
Phone [717] 285-4844

N. H. FLICKER & SONS INC.

Maxatawny
Phone [215] 683-7252

KELLER BROS.

Ridge Road
Perkasie PA
Ph: 215 257-5698
or 257-5864

PAUL J. EICHERT & SON

RD1 Orwigsburg PA
Ph: [717] 943-2304

NEW VOCO FARM WHITE

VOCO II IS THE PROVEN WHITWASH THAT IS NATURALLY ADHESIVE.

Voco II is NOT A LIME whitewash
Voco II will not flake or scale off

Voco II dries white.

APPLIED BY

RICHARD R. FORRY

Spraying

2020 Horseshoe Road
Lancaster, PA
Phone 717-397-0035

We are also equipped to serve you with modern equipment in all your areas of crop spraying