

Wants To Rent

WANTED

To rent or buy poultry farm. On long term lease. Should be large capacity.

Write P. O. 266F, Lancaster Farming, Lititz, PA 17543

Situations Wanted

Agri-business salesman desires job in Eastern Pennsylvania. Excellent track record. Write, c/o Box 266N, Lancaster Farming, Lititz, PA 17543

Farm Equipment



Peace On Earth

Peace... love... joy. To our good friends far and near throughout the holidays.

COPE & WEAVER CO.
New Providence

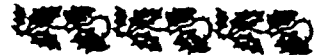

A C Model B power unit w-starter and PTO
Myer's Pump Jacks No. 8 and 10 New Idea Spreaders
New and used wagons
McCormick Deering Corn Binder Loaders
Wisconsin 4 cyl. engines
Meyer conditioner parts
Oliver 2B 12", 14" and 16" Plows.
We build sprayer and booms to fit your needs.
BEN FISHER
73 South Ronks Road
RD1, Ronks, PA

Pets

For Sale - Black Female Labrador Retriever, 5 mos has shots, also papers 717-626-5454 after 4:30



NEW EQUIPMENT

- White 348 3B 14 SAR Plow
- White 348 3B 16 SAR Plow
- White 548 6B 16 SAR Plow
- White 458 Chisel Plow 10
- Brillion 11 Cultivator
- Brillion 12 Cultivator
- Brillion 13 4 Cultivator
- Brillion 14 Cultivator
- Brillion 10 3 pt Chisel Plow
- Pittsburgh 2B 12 3 pt Plow
- Pittsburgh 2B 14 3 pt Plow
- Pittsburgh 55 3 pt Disk
- Pittsburgh 77 Wheel Disk
- Bush Hog 9 Disk Harrow
- Bush Hog 103 Disk Harrow
- Bush Hog 13 10 Disk Harrow
- Harvest Handler 16 Elevator

USED EQUIPMENT

- Oliver 348 3B 18 SAR Plow
- Oliver 2B Trailer Plow
- M M 14 3B 3 pt ST Plow
- A C Plow 1B fits B
- A C Plow 1B fits G
- Mads 6' 3 pt Chisel Plow
- Sauder D2 manure loader
- Oliver 356 3 pt Mower
- Oliver 242 Disk Harrow 12 8
- Case Manure Spreader
- N H Manure Spreader
- J D KBA Disk Harrow
- Fox Super 6 Harvester
- Gehl Harv w/cn hd

SPECIAL WHITE

- 348 Plow
 - Spring Auto. Reset 3-16" Bottoms
 - Spring Discs
 - Cover Boards
 - Rolling Landside \$1,750.00
- Offer Good Til Dec. 31 (only 3 Left)

FARMERSVILLE EQUIPMENT, INC.

RD2, Ephrata, Pa. 717-354-4271

Store Hours
Daily 7 30 6 00
Sat 7 30 4 30

Pets

Border Collie puppies - purebred - males \$45.00. Females \$40.00. Allan Case, Brodbeck, Pa. 717-235-2050

Farm Equipment

For Sale - New Idea 705 Diesel Uni-tractor. Excellent condition, 975 hrs \$13,000 or Best offer Sheller or chopper attachments available. 215-933-7379

Wanted - John Deere 730 Diesel on rubber in good condition. Phone Grant at 215-368-0560

Farm Equipment

FOR SALE
Sauder 7 ft. NOW PLOW
New Condition
302-658-6474

MANURE PITS
36 ft., 48 ft., and 60 ft. diameter. 12 ft. depth, circular precast concrete with gunite coated interior.
ZIMMERMAN INDS. INC.
RD1, Ephrata, Pa. 17522
Phone: 717-733-6166

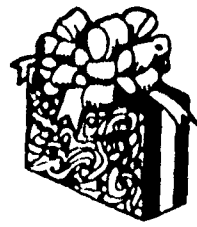

NOEL

Season's greetings and best wishes for your happiness. To our loyal customers... sincere thanks.

ROY H. BUCH, INC.
Ephrata 859-2441

Used Feed Grinder-Mixer, Roller Mills, PTO corn shellers, Manure spreaders, disc harrows, plows, loaders for tractors, auxiliary electric plants, tractors with loaders, skid steer loaders, large selection of tractors, wheel & crawler type, skid steer loaders with backhoes, Fork lifts, Duetz & David Brown tractors, chisel plows.
CLYDE E. KEENER
1531 Manheim Pike
Lancaster, PA 17601
Intersection of Rts. 72 & 283
Phone 717-563-9861

SPECIAL SPECIAL SPECIAL YEAR END SAVINGS

ONLY 2 WEEKS LEFT



For Better Milking IT'S BOU MATIC
Fastest Growing Milking System In The Nation.

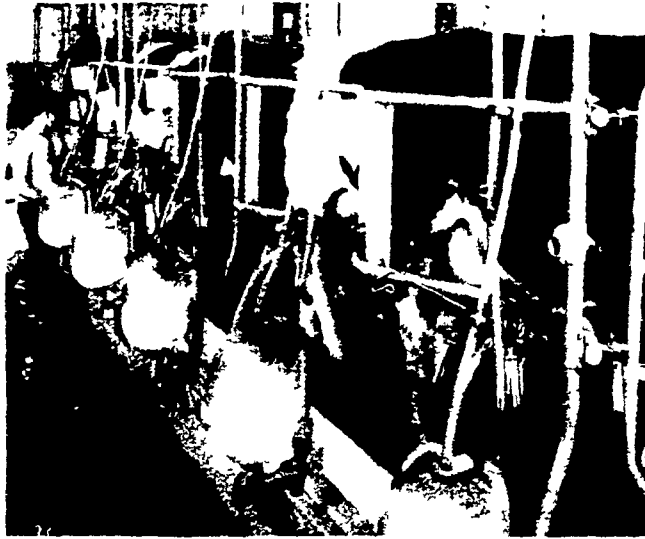

DARI-KOOL BULK MILK TANK

SAVINGS OF \$250.00 TO \$2500.00

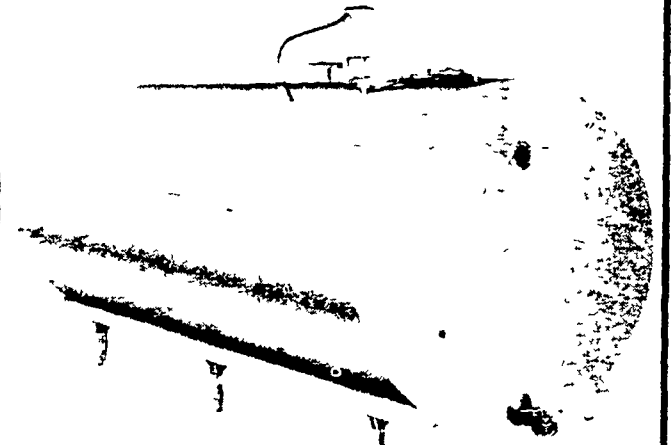

Model DKE - Direct Expansion
450 to 3000 Gal. Tank

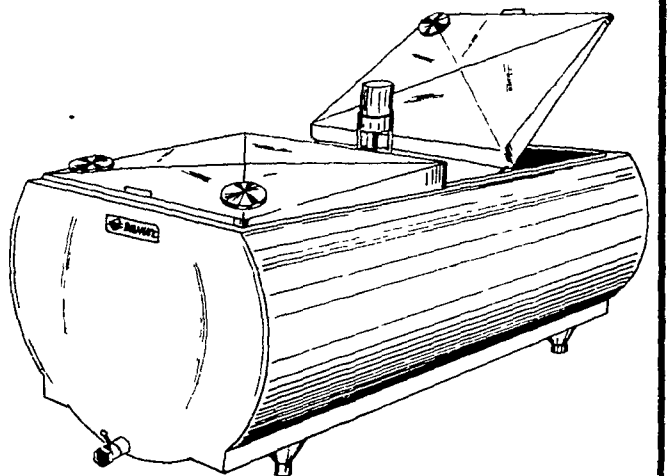

Model DKE Direct Expansion
Available - 500 Gal. Only
Special Diesel Operated Milk Tank

USED EQUIPMENT

- 12 can Open Top Can Cooler
- 10 can open top can cooler
- 6 can open top can cooler
- 4 can open top can cooler
- 800 Gal. Mojonier 5 H.P. belt driven compressor w/washer
- 625 Gal. Sunset flat top absolutely in new cond.
- 425 Gal. Esco \$400.00
- 400 Gal. Jamesway

LIQUID MANURE EQUIPMENT



Husky

"BETTERBILT"

- Trailer Mounted Pumps 8-10-12 Ft.
- 3 point Hitch Mounted Pumps
- Tanks - 1250 gal.
- 1875 gal. Tandem
- 2500 gal. Tandem
- 3,000 gal. Tandem

Vacuum Spreaders

- Model 800 gal.; 1100 gal.; 1500 gal.; 2100 gal.; 3100 gal.

30% DISCOUNT ON GRAIN BINS

DON'T WAIT READ DON'T WAIT

GRAIN STORAGE BINS

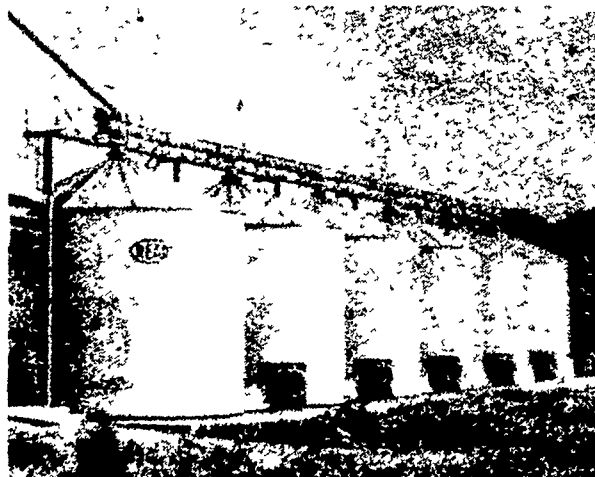

Inquiries invited from outlying areas.

COMPLETE PROGRAM SALES-INSTALLATION-SERVICE
24-Hour Service Offered

SHENK'S FARM SERVICE

501 E. WOODS DRIVE, LITITZ, PA 17543 PHONE (717) 626-1151

FRIENDLY Greetings



TO YOU

We wish to all our friends the merriest Christmas ever! Thank you for your valued patronage.

SHARTLESVILLE FARM REPAIR SERVICE

Shartlesville, PA (215) 488-1326

H. DANIEL WENGER, PROPRIETOR