

THE TIME IS RIPE

for selling, buying and moving. Beat the rush! Dairy Farm with all the trimmings. This beautiful 240 acre farm sits above a breathtaking view. Commanding 2½ story frame and aluminum farmhouse, Tenant House, and Georgian style pointed stone home, built circa 1735 with everything you expect completely restored. Sturdy rustic barn and many outbuildings. Frontage on Route 222. 140 acres tillable. Southern Lancaster County.



215 West Fourth Street
 Emory D. WAGNER Co. Quarryville, Pa. 17566
 Realtors
 (717) 786-2131 or 786-3020

For Sale - Farm. 4 barns, a tenant house, 6r with bath. Main house 12 rooms with 4½ baths. More Information: Box 59, St. John's, Pa. 18247.
 208 acre modern hog farm, farrow to finish, 4,000 head annually. Harold Fries, P.O. Box 149, Bedford, Pa. 15522. 814-623-9223.

REAL ESTATE WANTED

To be used for a cow-calf operation, ground should test 6.0 PH or better, should be 80 percent tillable, should have a small stream or good water supply, need 150 to 300 acres, be able to grow most crops without limitations, soil must have good drainage environment, will not consider too steep or stony ground, would like dwelling to be basically stone, expect to run 15 to 20 percent of this ground in pasture and cultivate the rest for crops. Would like to have the ground not near any large cities. Must have good secondary roads to the farm.

If the farm you are recommending for us has financing arrangements, please include these in your details.

If you know of such a farm, will you please send the information to me with all pertinent details.

Please Write or Call: Doug Terry

ROBERT F. FELTE, INC.

5 N. York Road, Willow Grove, PA 19099
 Phone 215-OL-9-1400

Real Estate

Wanted - 28-year-old farmer desires to lease modern dairy farm with facility for 50 or 60 cows and 125 or more tillable acres. Would like to lease for Oct. 1st but like to have terms of lease now for financial arrangements. Call between 9 p.m. and 10 p.m. 301-357-4351

BUYER'S DREAM

700 acres, large barns with feed lot, auto. feeders for hundreds of cattle, 5 large Harvestores, 3 homes, ponds. Up for quick sale at less than \$400.00 per acre.

BLUE BALL REALTY
 Blue Ball, Pa. 17506
 717-354-4536

250 A, Limestone, 70 stalls, pipeline, 2 barns & 2 houses, stream.

212 A, 50 stalls, ig. stone mansion, 6 fireplaces, Imme. poss. with crops.

88 A, 48 stalls, barn cleaner, milk transfer, silos, nice home.

154 A, 54 stalls, 2 Harvestores, stone home, pond, Lanc. Co.

84 A, 40 stalls, 4 silos, bunk feeder, nice home, fireplaces.

135 A, 24 sow heated farrowing house, nice beef barn, lovely brick home.

330 A, level limestone, all tillable, 2 sets bldgs.

229 A, limestone, 68 stalls, 2 new silos.
BLUE BALL REALTY
 Blue Ball, PA 17506
 717-354-4536

WE SALUTE ALL DAIRYMEN OF LANCASTER AND SURROUNDING COUNTIES

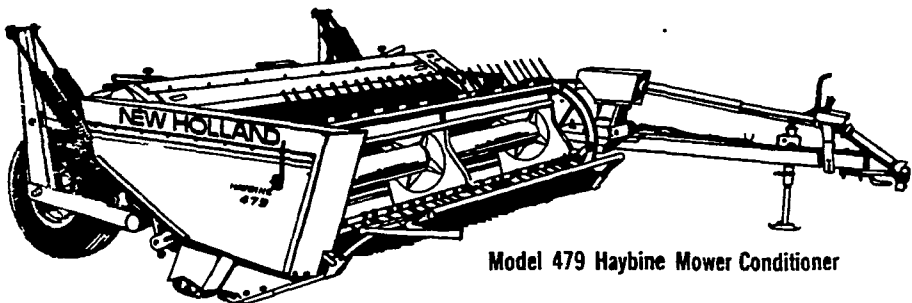

Model 479 Haybine Mower Conditioner



BALERS HAYBINES
 RAKES MOWERS

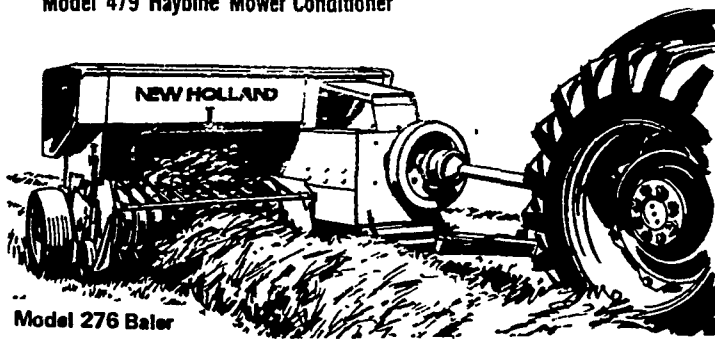

Model 276 Baler

WE WELCOME YOU TO STOP IN AND SEE OUR COMPLETE LINE OF NEW AND USED EQUIPMENT.



WE'RE YOUR LUBRICATION HEADQUARTERS

1 - Co 1/00 International Truck with Roll Back Bed (Very Good Cond.)

1 - 1890 IH Truck Conventional - 16 Ft. Bed, Clean

USED EQUIPMENT

Farmall 806D
 Case 300 w/Hydraulic Loader
 Farmall 240
 Int. 454 3 Pt. Hitch
 I.H. 424 w/Loader
 650 Harvester w/Screen Pickup Head
 N.H. 1469 Self Propelled Haybine
 Badger Self Unloading Wagon
 Smoker Elevator 24 and 30 ft.
 Case 9 ft. offset disk
 Sauder Loader
 I.H. 550 Plow 5-16"
 Midwest Lift Harrow Fits 12 ft. Disk

LAWN & GARDEN

60 Cadet 700 Wheel Horse
 110 John Deere Reo Rider



MESSICK FARM EQUIPMENT INC.

2750 N. MARKET STREET

PHONE 367-1319;

ELIZABETHTOWN, PA

JOHN KREIDER HOME 367-6039

WARREN SPICKLER HOME 653-4560

IN MINT CONDITION ONLY \$22,900.

This completely remodeled log house will not last long. Country setting in Southern Lancaster County. Beautiful hard wood floors, slate entryway, eat in kitchen, living room with exposed log wall.

Call Paul Horst
 For An Appointment Today.



YATES and SCHUYLER COUNTIES NEW YORK STATE

FARMS all types and sizes Homes Businesses. Call anytime 607-243-7410 or write

STOCKING, Broker Dundee, NY 14837

12½ acre beef and hog farm in Snyder Co. (Middleburg area) 38 x 46 barn loam-type soil 1½ story frame house well and stream.

Southern Lancaster Co. - 70 acre dairy farm, milking parlor, loafing pen 9-room frame & log house.

Steer & chicken farm of 160 acres in Juniata Co. Port Royal area. All buildings in good condition, 5-bedroom house about 130 acres tillable.

148 acre dairy farm one mile south of Marticville. Large stone and frame barn in good condition. Harvestore and concrete stave, corn barn, tobacco shed. 8-room house in good condition. Also tenant house with 7 rooms, small barn and garage.

118 acre general farm about one mile from Northumberland. Producing soil, road frontage.

163 acre general farm about 25 miles west of Harrisburg. 100 acres tillable. Buildings in good condition. Approx. 50 acres woodland. Also road frontage.

83 acres land, no buildings, two miles south of Lawn on Route 241, bordered on north by Pa. turnpike. Partially wooded, sloping, good drainage.

131 acre steer farm in Bethel Twp. Frystown area. Limestone soil. 3 acres fruit. Large barn and double house. 2 wells and 2 streams. Some road frontage. Lease purchase available.

30 acres land with frame barn, apartment house, brick mill. 10 acres meadow, 2 acres woodland 2 wells, spring. This is unusual property located in Lebanon Co. (Fredericksburg area).

60 acre dairy farm in Chester Co. near Morgantown Interchange. Farm overlooking a beautiful large lake. Land adjoins lake property. Has very nice slope towards lake. 8-room house in good condition. Large barn and milking stable. Silo, corn barn, machine shed.

13-acre farmette near Lancaster. 750 road frontage. Zoned residential.

Please call our office for further details on these and our other listings.

CHRISTIAN M. MOSEMAN, Realtor

734 Main Street, Akron, Pa.
 Phone Office 859-1004 or 733-1224