

classified ads

Phone 394-3047 or 626-2191

Real Estate

52 acre farm in Morrisons Cove, Bed. Co. Never failing spring through yard. Contact Bernard O. Snider, New Enterprise, Pa. 16664

FARMS FOR SALE

116 Acre dairy farm in Berks County with a 4-bedroom house, barn with 41 tie stalls, 3 silos, an implement shed, butcher house, garage, and many other extras. Priced at \$133,500.

92 acre good productive dairy farm in Lebanon County with 2 houses, 2 barns, 2 silos with unloaders, stream, and other extras. For more information on these properties, Call Realtor Associate Bob Smith, 717-866-5959 of Derry Realty Company.

Real Estate

365 A level limestone, modern dairy, 106 free stalls, 2 sets bldgs. 20 year 7 percent mortgage.

263 A new 100 cow barn, lg. modern stone and frame home.

163 A cattle ranch, good house and barn, stream.

77 A dairy farm, good bldgs.

61 A stone mill, 2 homes.

BLUE BALL REALTY
Blue Ball, Pa.
717-354-4536

For Rent - 102 acre Dairy Farm - milking equipment included - Modern home, Lebanon County. Call 215-666-5455. Available April 1st. 1975.

Real Estate

Farm for Sale consisting of 100 acres more or less, 2 large houses, new barn and implement shed. Running water in barnyard from a spring. Lot of road frontage 3/4 miles. See Howard Snyder, Red Lion, Pa. RD1.

Wanted to Rent - Pasture for beef herd year round desired. 90 to 200 acres, must have good water and good fences. Call 215-388-6119, Chadds Ford, West Chester Area.

For Rent - Deluxe mobile home on lovely horse farm. Available for reduced rent in exchange for occasional caretaker or handyman work. Adults. Phone 717-665-3983

Real Estate

ACREAGE

30 Acres adjacent I-78 and just 15 minutes from Lebanon. Many possibilities. Owner will sub-divide. \$1500 per acre.

28 Acres with large 4 bedroom farm house, good barn and out buildings, orchard, and handy location, Lebanon Co. \$79,500.

4.6 Acre woodlot. Be great spot for chalet or A-Frame. List at \$11,900.

SUBURBAN REALTY

930 Cornwall Road
Lebanon, Pa. 17042
Phone 717-273-9358

Real Estate



FULL SERVICE REALTOR

MULTIPLE LISTING SERVICE

Corner of Route 41 and Route 1 By-Pass

CHESTER COUNTY

40 Acres, house and barn - \$75,000.

117 Acres, with milking parlor, modern loose housing set-up for dairy or general livestock - \$220,000. Owner Financing Available

325 Acres - Near Delaware State Line, 250 Acres tillable Self-unloading silos with 100' feeder, large dairy barn and restored silos with 1 farmhouse - \$650,000. Owner Financing Available

CENTRAL PENNA.

(3) 100 Acre good working farms in Juniata and Dauphin Counties - \$1,000 to \$1,200 per acre.

N. E. PENNA.

470 Acre Farm in Susquehanna County on the outskirts of Montrose - Modern dairy barn, heifer barns and 3 houses - \$400,000. Owner Financing Available

(215) 869-8711
Anytime
(215) 692-8281
9 a.m. - 6 p.m.



FOR THE BEST HEDGE AGAINST INFLATION
BUY QUALITY REAL ESTATE

ON THE HOUSE

BEAUTIFUL FINGER LAKES AREA

185 acres, 165 tillable acres of good land 47 free stalls, milking parlor, 2 silos, bunk feeder, mow conveyor, 8 room home, stocked and equipped.

2 bedroom year around home, fireplace, furniture, 60 foot of very good lake front on small lake.

3 bedroom year around home, large modern kitchen, large living room, 2 baths, full basement, garage, attic could be used for bedrooms, 150 foot of nice beach, Keuka Lake, affords family fun with good fishing. \$70,000.00.

265 acres, 200 tillable, new 3 bedroom home, no barn, picture book view of lake and hillsides. \$85,000.00.

J. R. Allen Realtor
Dundee, N.Y. 14837
607-292-3180

DAIRY FARMS

55 acres in Lebanon Co., 32 stalls, bulk tank, barn cleaner, loafing and calf pens. All buildings and equipment in excellent condition. Stone house built in 1900 with attached summer house. Modern conveniences. 4 acres meadow with stream thru farm, also 3 acres woodland.

93 acres in Northern Lancaster Co. 40 x 90 concrete block & frame barn built in 1968, 40 stanchions, 2 silos, sand soil, 15 acres meadow, over mile of road frontage. Wells & running water. 30 x 36 log house in good condition.

148 acres in southern Lancaster Co. 40 stanchions, 40 x 100 stone & frame barn, Harvestore, corn barn, tobacco shed. 8-room house in good condition with 7-room tenant house.

STEER FARM

100 acres or more in Bedford Co. 60 acres tillable, 26 A. meadow and 14 A. woodland. Has a beautiful 2-story house with many extras. 40 x 80 barn, wagon shed, corn crib, 2-car garage. Priced-reasonable.

GENERAL FARMS

30 acres in Bethel Twp., Lebanon Co., 10 acres meadow, 2 A. woodland. Frame barn 55 x 33. This property also contains brick mansion with 5 apartments, brick mill & carriage house. Has 2 wells and spring. Call about this unusual property today.

131 acres in Bethel Twp., Berks Co. Limestone soil, 3 acres fruit trees. Large barn and double house with conveniences. 2 wells & streams. Has road frontage.

We have land in Adams Co. at \$1100 per acre located just off new Route 15 at Gettysburg. One estate of 300 acres (100 acres woodland) and the other property consists of 100 acres with brick house built in 1900 in good condition

CHRISTIAN M. MOSEMAN

REAL ESTATE BROKER

734 Main Street, Akron, Pa. 17501
Phone 859-1004

MINNESOTA

240 ACRE OPERATING CORN, SOYBEAN OR STOCK FARM

25 minutes west of Mayo Clinic in Rochester Large house, barns, cattle sheds and 2 new 20' x 60' silos with unloader 220 acres tillable with deep, black soil, balance pasture with stream Unusual opportunity for farmer at \$675 00 per acre Good financing available Call owner 609-235-3079

L. H. BRUBAKER, Inc.

AUTHORIZED DEALERS FOR ALLIS CHALMERS & NEW HOLLAND FARM EQUIPMENT

HAY TOOLS — ELEVATORS

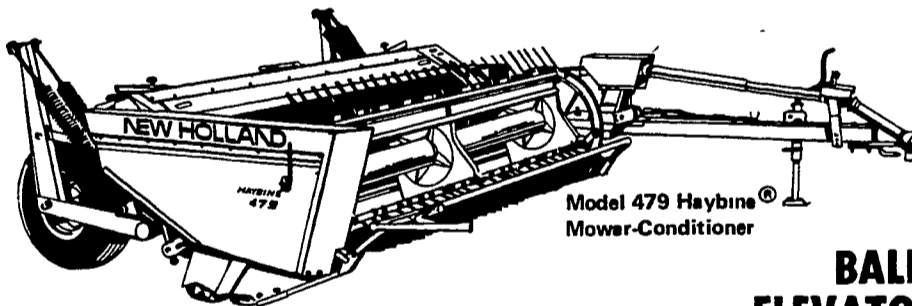

Model 479 Haybine® Mower-Conditioner

65 Massey Ferguson Tractor (Excellent Cond)

Now Available With Waver of Finance

BALERS, HAYBINES, ELEVATORS IN STOCK FOR IMMEDIATE DELIVERY

USED EQUIPMENT

- | | | |
|------------------------|------------------------------|-------------------------|
| SP 1469 NH Haybine | 469 N.H Haybine | 2 - 145 Bushel Starline |
| SP 310 Hesston Haybine | 35 IH Spreader | Spreader |
| 268 NH Baler | 717 NH Forage Harvester | 3 Point Snow Blower |
| 78 NH Baler | Grove Forage Wagon | Shaver Post Driver |
| AC 303 Baler | Gehl Forage Wagon | AC (2) Row Corn Planter |
| 37 IH Baler | Vemere Hay-Crusher | |
| AC 303 Baler w-Engine | 12A N.I Spreader | |
| AC 80R Mower | 206 NI Spreader | |
| JD Side Mounted Mower | 185 Bushel Farmhand Spreader | |

CHECK WITH US FOR YOUR EQUIPMENT NEEDS

WE WILL DEMONSTRATE

Full Line of Simplicity & A.C. Lawn and Garden Equipment

WE ARE A FULL SERVICE DEALER ON STARLINE PARTS

FREE ESTIMATE ON RECONDITIONING YOUR FARM EQUIPMENT.
FREE PICKUP AND DELIVERY IF BOOKED DURING THE MONTH OF JANUARY

CALL DICK BONHOLTZER 397-5179
SHOP FOREMAN

CONTACT
BOB GANTZ — HOME 653-5020
OFFICE — 397-5179
OR 687-6002

L. H. BRUBAKER, Inc.

350 Strasburg Pike

Ph. 397-5179

Lancaster, Pa.