

Solanco 4-H Club

The Solanco Community 4-H met on Friday, June 14, 1974, at Jim Kreider's. Games started at 7:30 p.m. and members played volleyball and baseball.

The next meeting will be held at Melvin Eckman's on July 11, 1974, at 7:00 p.m. It's

going to be a cook-out with lots of fun and good eating. If interested in becoming a member of 4-H come and join the fun. To join 4-H you must be between the ages 8 and 19. Invite your friends!

Lisa Thompson,
News Reporter

Lancaster Co. 4-H Teams Organizing

Interested in representing Lancaster County at 4-H State Days? An organizational meeting for various teams to attend this event will be held July 1, 1974 at 7:30 p.m. at the Farm and Home Center.

All the counties in Pennsylvania select teams to compete at 4-H State Days. Lancaster County has had winning Dairy, Horse, Livestock, and Consumerama teams in the past years. This year these teams will again be competing and some new teams are being formed. You and your 4-H friends can qualify for these teams if you: (1) are over thirteen years old, (2) are enrolled in a team project area, and (3) have completed one year of 4-H Club work. Each county can send a team of four

members. Boys and girls are eligible.

Team categories and the person working with the team are: Entomology, Flower and Horticulture Judging, Mr. Arnold Lueck, Associate County Agent; Meat Judging, Mrs. Doris Thomas, Home Economist, and Mr. M. M. Smith, County Agent; and Poultry Judging, Mr. Jack Renshaw, from Pennfield Corp.

Two team events are open to any 4-H'er regardless of their project. The Consumerama team is four members who will be judging products, answering questions, and making wise consumer decisions. Miss Anne Hinkel, Assistant Home Economist, and Miss Debra Gregory, 4-H Summer Assistant, will work with the Consumerama team.

The Physical Fitness Team will have eight members who will be timed against other participants. The event consists of running, sit-ups, jumping, and throwing. Also, Physical Fitness team members will learn how nutrition contributes to good health. Mrs.

Tillie Gibson, Nutrition Aide Supervisor will work with the Physical Fitness team. All 4-H members and leaders are invited to come to the meeting on July 1st to learn more about these teams. For further information contact the Extension Office 394-6851.

INTERNATIONAL HARVESTER GREENBACK SALE

LOOK WHAT ONE DOLLAR WILL BUY!

Get an Edger Trimmer or Hedge Trimmer for just \$1.00 when you buy a Cadet Riding Mower or Cadet Lawn Tractor.

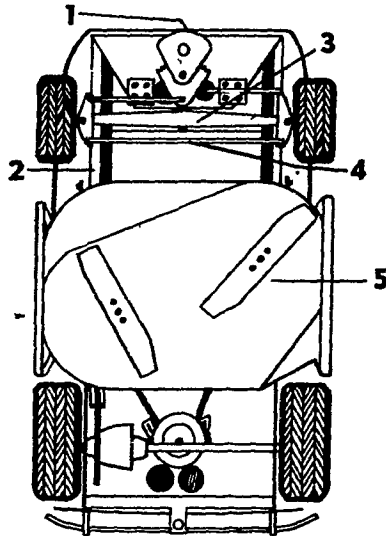

TURN US INSIDE OUT!

1. Maintenance-free Fiberglass Body
2. Channel Steel Frame
3. Heavy Duty I-B Axle
4. Adjustable Steering/Tie Rods
5. Safety Approved Side/Rear Discharge 32" Mower
6. Auto-Type Steering
7. Brake/Clutch Pedal
8. On-the-Go Height Adjustment
9. Three Speed Forward, One Reverse
10. 5, 7 Horsepower as well as All-Electric Model

or RIGHT SIDE UP

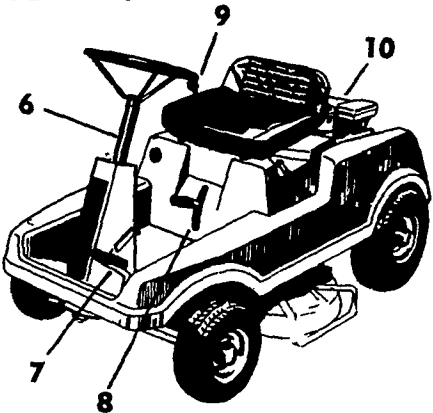

IH RIDING MOWERS THE QUALITY MACHINES AT THE PRICE YOU CAN AFFORD



INTERNATIONAL HARVESTER
1054 S. STATE ST.
EPHRATA, PA.
717-733-2283

C. B. HOOPER & SON
INTERCOURSE, PA.
768-8231

COPE & WEAVER
NEW PROVIDENCE, PA.
786-7351

MESSICK
2750 N MARKET ST
ELIZABETHTOWN, PA
367-1319

R. S. HOLLINGER & SON
113 WEST MAIN ST
MOUNTVILLE, PA.
285-4538

MARTIN HARDWARE & EQUIPMENT CO.
SCHAEFFERTOWN, PA.
717-949-6817

Miss Gregory New Summer Asst. in 4-H Youth Work

Debra Gregory, daughter of Mr. and Mrs. Robert Gregory, Lititz RD1, has been employed as a summer assistant in 4-H youth work by the Lancaster County Extension Service. She will



Debra Gregory
be assisting the local extension staff in coordinating

and developing the Lancaster County 4-H Club Program.

Miss Gregory is a student at Penn State University, College of Human Development, majoring in home economics education. She has had 10 years of 4-H work in Lancaster County

with projects in clothing, cooking, dairy, horse, and strawberry growing. She also was active in the Lancaster County 4-H County Council.

Her current responsibilities include training club leaders, developing club programs, preparing the county delegation to the Club Congress and the State 4-H Festival, and planning the County 4-H Achievement Day.

New Holland 4-H Club

New Holland 4-H Community Club met at St. Stephens Reformed Church on Monday evening June 17. The club nominated Jeanie Martin as Junior Queen but will not be able to have a Senior Queen because of conflicting schedules. Arnold

Lueck showed a slide presentation concerning 4-H in Lancaster County. The meeting will be July 15 at Bill Fisher's and it will be a swimming party with a special invitation to the parents of the club members.

Farm Youth Calendar

- Tuesday, June 25
Busy Bakers 4-H Cooking Club Meeting
7:30 p.m. - Penn Manor Community 4-H Club Meeting at the home of Stacy and Kim Carl, Hershey Mill Road.
Wednesday, June 26
4-H Dairy Judging Practice in Lancaster County.
9:30 a.m. - Leave Farm and Home Center
10:00 a.m. - Masonic Homes Elizabethtown
1:00 p.m. - S. R. Shellenberger Farm
4:00 p.m. - Return to Farm and Home Center
Members are Asked to bring their lunch.
Thursday, June 27
7:30 p.m. - Lancaster County 4-H Holstein Dairy Club Meeting, at the J. Mowrey Frey Jr. farm, Lancaster, Route 222.



SILAGE BOOSTER

BY THE TRUCKLOAD OR BY THE BAG:
FREE GIFT WITH 4 BAGS OR MORE
ONLY \$190.00 FOR A 20 x 60 SILO.

IT'S GREAT FOR TOUGH HAY!

COMPARE McNESS

YOU CAN FIND OTHER GOOD ONES. YOU CAN PAY MORE - BUT YOU CAN'T FIND A BETTER PRODUCT FOR PREVENTING SPOILAGE OR PRESERVING NUTRIENTS. - NOT CORROSIVE.

CONTACT McNESS

BOX 140, EAST EARL, PA. 17519
PHONE 215-445-6983 OR 717-733-7541

WE SPECIALIZE IN PREMIX TOO.



Old Guard

Mutual Insurance Company

"Friend of Farmers since 1896"

1810 Oregon Pike
Lancaster, Penna. 17601

A Company founded by a group of Lancaster County farmers. We understand your insurance needs and we can give you the protection you need without the fancy frills. This results in lower rates for you. See our agent in your area.

LOOMIS INSURANCE AGENCY
ADAMSTOWN, PA.

JACOB N. MARTIN
R.D.2, LANCASTER, PA.

LUKE M. MARTIN
367 VALLEY VIEW DR., NEW HOLLAND, PA.

Fun — Thrills — Excitement
IF YOU HAVEN'T BEEN THERE

— GO —

IF YOU WERE THERE
YOU WILL GO AGAIN



BUCK TRACTOR PULLS

PA. STATE SANCTION CLASS A

FRIDAY, JUNE 28 - 7:30 P.M.

SATURDAY, JUNE 29 - 7:30 P.M.

GENERAL ADMISSION
\$2.50

RESERVED SEATS
\$2.75

Under 12 - \$1.50

BUCK TRACTOR PULLS LOCATED ON RT. 272
10 MILES SOUTH OF LANCASTER