

Strasburg Bank Appoints Smith

R. Scott Smith Jr. has been appointed director of marketing, advertising and public relations for The First National Bank of Strasburg.

In his new post, Smith will coordinate bank marketing and research development and will administrate all advertising and public relations programs.

Prior to joining The First National Bank of Strasburg, the Lancaster County native was market research analyst and regional marketing coordinator of the Southeast National Bank in Chester, Pa. He completed their management trainee program.

Smith holds a B.S. degree in finance from Pennsylvania State University and is presently enrolled in Widener College's



R. Scott Smith

MBA program. He is a member of the Bank Marketing Association and attended their School of Bank Marketing in Boulder, Colorado.

Smith is a 1965 graduate of Solanco High School in Quarryville. He and his wife and one-year old daughter reside in Lancaster Township

TRY A
CLASSIFIED AD!

Living Standards, Food Prices Topic of Slide Set

A new color slide presentation, which shows the role farmers and others in the agricultural complex have played in freeing the American public from the need to grow its own food, has been released by the Photography Division, Office of Communication.

Titled "The Peaceful Revolutionists," the 195-frame set tells what took place in agriculture and related fields over the past 25 years to produce a revolution that has freed an entire Nation from the soil to make this country the most literate, the most affluent, and the best fed Nation in the world.

It includes information about today's food prices, eating habits, and how they compare in terms of average wages with other countries, and with the past.

The slide set is available from Photography Division, Office of Communication, U.S. Department of Agriculture, Washington,

FFA members from Lancaster and Chester Counties met at the Brownstown Vo-Tech School Tuesday to determine area winners in Parliamentary Procedure and Public Speaking competition. Top winners in the area event will go to the regional contest May 15 at Lehigh Community College, competing with students from 19 eastern counties.

Top winners in the Public Speaking event and the titles of the speeches chosen for presentation were: Ray Martin, Garden Spot Chapter, "The Food Dilemma", first; Robert Hershey, Manheim, "Our Vanishing Wildlife", second, and Doris Deavor, Central Chester Vo-Tech, "Pollution Seven Years Later", third.

Other contestants in the Public Speaking contest were Howard Stoltzfus, Owen J. Roberts Chapter; Ronald Kreider, Manheim, and Kenneth Kybury, Owen J. Roberts.

Judges in this event were Jay Hollinger, sales manager of special products, Victor F. Weaver, Inc.; Ed Moshier, farm director, WHEX, and Harvey Smith, vocational consultant for Lebanon-Berks-Schuylkill area.

Grassland Chapter, successful in capping county competition, won first place in the area contest. Other placings were: Cloister Chapter, second, Oxford Chapter, third, and Octorara

Chapter, fourth.

Members of the top two teams and the offices assumed were: Grassland Chapter -- Scott Steffy, president; Donald Weaver, vice-president; David Smeltz, secretary; Clair Martin, treasurer; Donald Weiler, reporter; Larry Weber, sentinel; Arthur Horst, student advisor; Lloyd Hoover, chaplain.

Cloister Chapter -- John Weaver, president; Melvin Weiler, vice-president; Richard

Bollinger, secretary; Paul Horning, treasurer; Marlin Smoker, reporter; Leonard Martin, sentinel; Barry Wissler, student advisor; James Felpel, chaplain.

C. F. Lebo, program specialist at the state office in Harrisburg, R. W. Harrison, vocational consultant in the eastern area, and Russell Drumm, Denver RD1, landscape consultant and former agriculture teacher, served as judges.

TRUCKS FOR SALE

- 1968 Ford 10 wheel dump
- 1969 Ford 10 wheel dump
- 1968 Int. 10 wheel dump
- 1968 Int. Tri-axle dump
- 1966 G.M.C. Tri-axle dump
- 1968 Ford single axle dump
- 1964 Ford 10 wheel dump
- 1963 Chevy 10 wheel dump
- 1960 Mack 10 wheel dump
- 1965 Mack 10 wheel dump
- 1956 Reo 10 wheel dump
- 1961 Chevy single axle dump
- (2) 1962 Ford single axle dump
- 1968 Ford W1000 Truck-tractor
- 1955 Mack truck tractor
- 1961 G.M.C. truck tractor
- 1958 Mack truck tractor
- 1970 Int. C4070A truck tractor
- 1956 Mack truck tractor
- 1966 Ford 750 twin screw cab and chassis
- 1969 Ford 700 cab and chassis
- 1967 Ford 700 cab and chassis
- 1968 G.M.C. 5500 cab and chassis
- 1970 Ford Louisville (you must see to appreciate)
- 1965 Ford single axle dump
- 1965 G.M.C. 4000 Flat bed
- 1970 Ford 10 wheel dump
- (3) 1963 G.M.C. 10 wheel dump
- (2) 1972 Int. Transtar - 318 engines
- (2) 1963 Int. single axle dump

Excellent Selection and Still more Coming.

WENGER'S FARM MACHINERY, INC.

So. Race St.
Myerstown, Pa.
Ph. 717-866-2138

No Other Protein Need When You Feed



SPECIAL TANVILAC

Feeders Say . . .
"The Most Economical Feeding Plan of All"

USE ONLY 1/2 LB. SPECIAL TANVILAC PER HEAD PER DAY WITH GRAIN AND ROUGHAGE -- GET BIGGER PROFITS

No trouble with scours or cattle going off feed. You'll be more than satisfied with our feeding program for you'll get healthy stock, quick gains at low cost. Remember, there's a FEED LOT PROVEN TANVILAC CULTURE PRODUCT FOR EVERY FARM-FEEDING PURPOSE.

FOR MORE PROFITS--MAIL COUPON
THE TANVILAC COMPANY, INC.
6th & Corning Aves., Box 96, Highland Park Station, Des Moines 13, Iowa
Please Send Me Additional Information about Special Tanvilac.

I have Cattle
NAME
ADDRESS



C. O. NOLT LOCAL DISTRIBUTOR

BIRD-IN-HAND

Phone Lanc. 397-0751

County Winners Top Area PP-PS Contests

NEW JAMESWAY Rugged Chain Barn Cleaner



Frees You for Better Things



- * Heavy Forged Link Chain
- * Galvanized Steel Elevator
- * Powerful Transmission

Stop In Today for Free Catalog.

YOU CAN COUNT ON US

LANDIS BROS., INC.

Phone 393-3906

1305 Manheim Pike

Lancaster, Pa. 17601

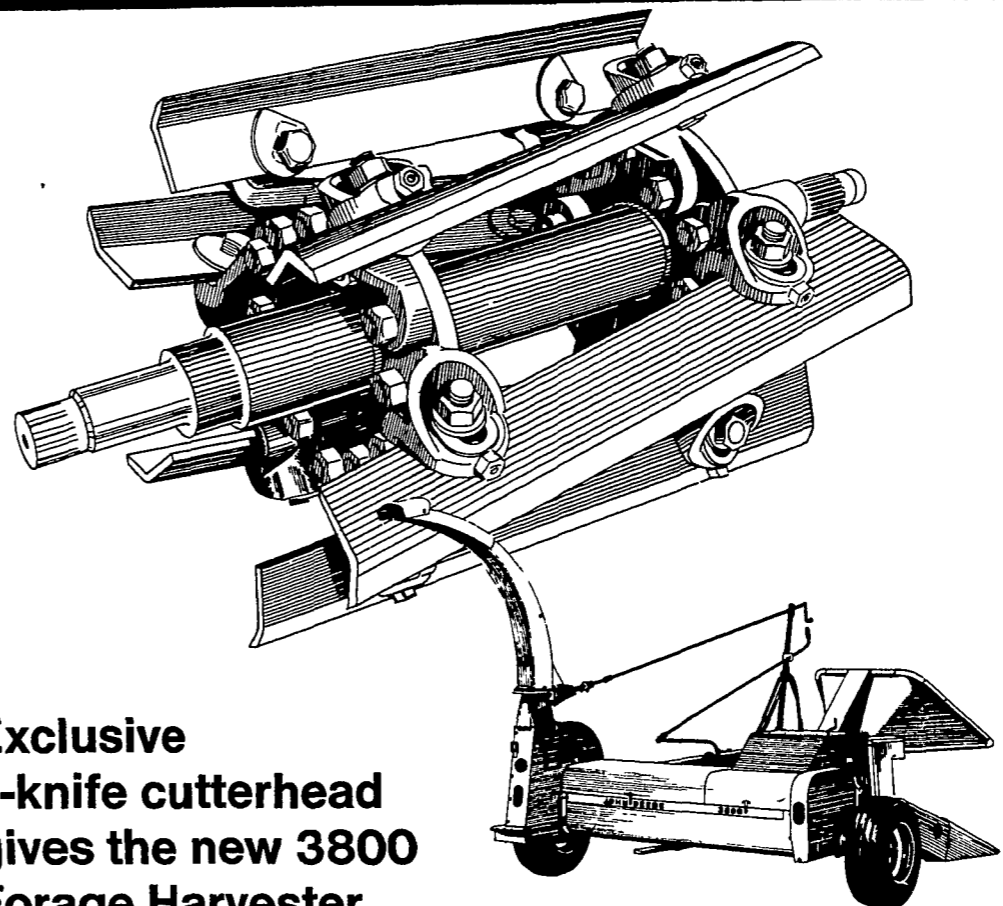

Exclusive J-knife cutterhead gives the new 3800 Forage Harvester the cutting edge

The heavier-duty 3800 is built to match the bigger horsepower of today's tractors.

J-knives propel chopped material out of the cutterhead like a paddle wheel . . . faster than conventional knives. The result is greater efficiency and more capacity.

J-knives are field-proven on

John Deere Self-Propelleds. So is the heavy-duty feed-roll drive with slip-clutch protection.

The new 3800 has heavier drives to and from the gearcase, greater frame strength, and larger fan shaft and bearings than other John Deere pull-types.

Stop in soon for full details.

EDWIN HURST INC.

Admstown Pa 215-484-4391

WENGER IMPLEMENT, INC.

The Buck 284-4141

LANDIS BROS. INC.

Lancaster 393-3906

SHOTZBERGER'S

Film 665-2141

A. B. C. GROFF, INC.

New Holland 354-4191

M. S. YEARSLEY & SONS

West Chester 696-2990

