

FHA Loans \$1 million To Flood Victims

Penrose Hollowell, State Director of the Farmers Home Administration announced Tuesday that Emergency and Disaster loans approved to rural home owners and to farmers have now passed \$1,000,000 in Pennsylvania. He stated that all FHA Offices in the state have given priority attention to victims of the disaster and that

additional personal are assigned to critical areas to meet the needs.

Under the Disaster Relief Act of 1970, owners of homes which were damaged or destroyed may be eligible for loans for replacement or repair of homes in rural areas or in towns with up to 10,000 population.

Weaver Promotions Announced

Three changes have been announced in the personnel department of Victor F. Weaver, Inc., New Holland, according to James L. Roth, Personnel Administrator.

M. J. Hochstetler, R D. No. 1, Gordonville, formerly employment supervisor has been promoted to employee relations supervisor; James R. Hess, 1675 Lincoln Highway East, Lancaster, formerly assistant employment supervisor, has been promoted to succeed Hochstetler as employment supervisor; and Earl B. Groff, 410 Roseville

Road, Lancaster, personal representative will succeed Hess as assistant employment supervisor

Hochstetler, a native of Indiana, joined Weaver in 1965 as a personnel assistant. In 1967 he was promoted to the position of personnel supervisor and more recently has held the position of employment supervisor

Hess joined Weaver's personnel department in 1971 as assistant employment supervisor. He is a graduate of Eastern Mennonite College where he received a bachelor of arts degree in English in 1951. Hess also pursued graduate studies in linguistics at the University of North Dakota.

Groff began with Denver Wood Products, Inc., a subsidiary of Weaver, in 1968 as a sales and procurement supervisor and later joined the parent company's personnel department as a personnel representative. He is a graduate of Manheim Township High School

In another move, Luke B. Sauder, Route No 1, Denver, was named to the position of safety supervisor.

Sauder joined the company in 1959 as a truck driver in the transportation department. In 1961 he was named to the position of assistant supervisor in the shipping department, and later held the post of dispatcher. In 1970 he was named to his most recent position as driver training and fleet safety supervisor.

Under his new duties as safety supervisor, Sauder will be responsible for developing and promoting programs that will create and maintain safety awareness in all Weaver operations.

* * *
Slip a cotton glove over the nozzle of your hose, fastening the wrist of the glove securely with wire or twine, when you water your garden or yard. Turn on water and lay the nozzle of the hose (inside the glove) in various places until the area is soaked. This gives a controlled flow of water and the plants will not be drenched with spray but will be perky and fresh.

xxx
Match your fire extinguisher with the fire. Be sure to read the operating instructions on your extinguisher: "A" type on paper or wood, "B" type on gas or oil, "C" type on electric fire.

xxx
A fire extinguisher is a small investment that could prove big in returns. Keep one in your home, your car and on all of your farm vehicles.

xxx
When repairing farm machinery, STOP IT, before working on it.

Under the same Act, farmers suffering loss of crop, livestock, machinery or buildings, may be eligible for loans to replace the losses.

Up to \$2500 of the Emergency or Disaster loans can be canceled and the remaining amount is repayable on terms up to 33 years at 5 1/2 interest.

Hallowell stated that all the Federal Agencies are working together in providing information and assistance to those who have suffered losses from the storm. He said that application for FHA assistance may be obtained from local offices for the Farmers Home Administration or from the County Agricultural Extension Service, Soil Conservation Service, or the Agricultural Conservation and Stabilization office in each County.

Smile!

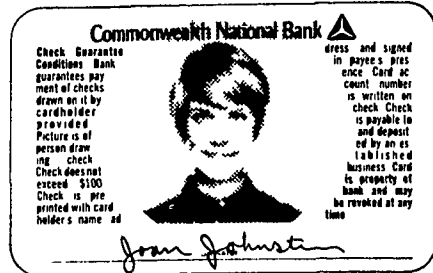

You're on Commonwealth Master Charge

Commonwealth National Bank 
The Master Charge Bank

AGWAY

STA-RITE CAN PUT A PIPELINE IN ANY BARN

WHY BUY A PIPELINE?

For An Average 40 Cow Herd

You Can . . .

1. Save walking 100 miles a year.
2. Save carrying 292 tons of milk a year.
3. Save 200 hours per year on an average herd.
4. Produce higher quality milk.
5. Increase your milk production.

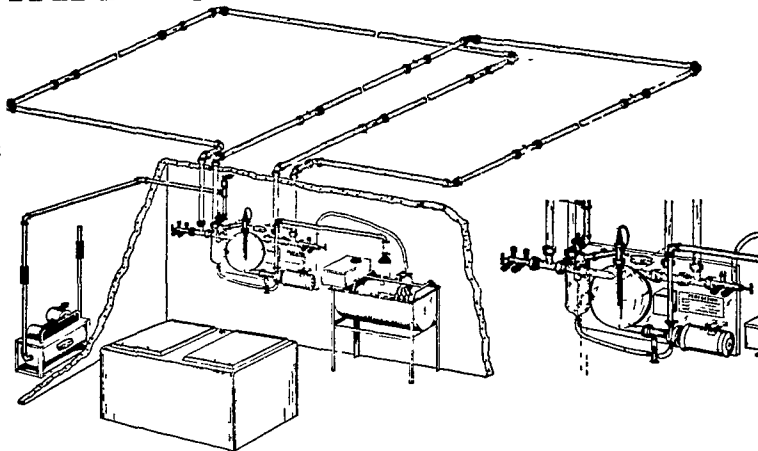

WHY BUY A STA-RITE PIPELINE?

1. Engineered for the modern dairy farm of today as well as the dairy farm of tomorrow. Around the barn pipelines and milking parlors.
2. The only milkhous control unit that is assembled at our modern new factory on a stainless steel panel. Pretested for trouble free operation, self-draining with patented washing features.
3. Built and guaranteed by Sta-Rite Industries, Inc., of Delavan, Wisconsin, a recognized leader in home water systems and agricultural components.

— 24 Hour Milking Equipment Service
— Installation and Service

CALL TODAY AND ASK FOR AN APPOINTMENT

MOVE UP TO THE NEW SUNSET "SPACE SAVER"

The Latest Development in
Stainless Steel Milk Coolers
for the Expanding Dairyman.

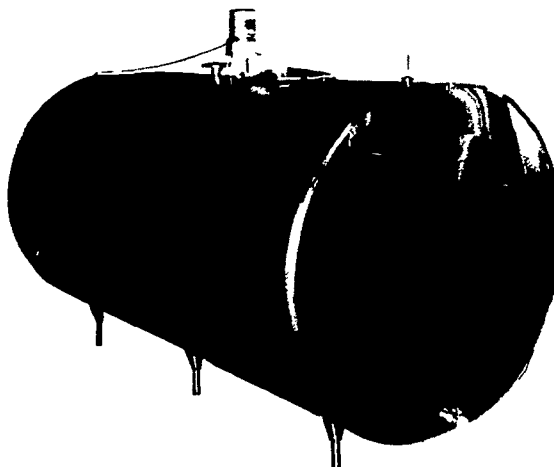

Move up in capacity without adding space. This efficient atmospheric cooler with the modern, elliptical shape gives up to 50 per cent more capacity in the same floor space.

Move up in versatility. "SPACE SAVERS" are "Advanced Evaporator" models which can be installed with one or two compressors, controlled from a dual refrigeration system. These "AE" designed coolers permit buying for your present production needs and allow future expansion at lowest cost.

Four "SPACE SAVER" sizes: 600, 800, 1,000 and 1,500 gallons.

Move up in convenience as you add capacity. The "SPACE SAVER'S" shape, with its single positive-closing cover makes it ideal for automatic Sunset Spin-Clean washing. It's easier, more thorough, more economical, with no overspray.

HAVING VENTILATION PROBLEMS?

SEE US!

WE OFFER THESE POPULAR MAKES

- AEROVENT
- ACME FAN JET SYSTEM
- VENT-O-MATIC
- CHORE-TIME
- AIR-O-MATIC
- COOL AIR

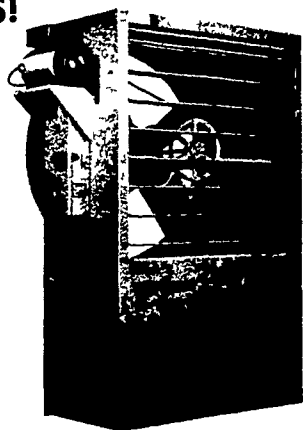

A controlled environment is essential, particularly during the hot summer months. Controlled even temperatures in Poultry and Livestock housing can only be achieved with individually designed ventilating systems. Let our engineers design a ventilating system to fit your needs. High volume air at low operating cost.

WE SELL, SERVICE AND INSTALL

E. M. HERR EQUIPMENT, INC.

R. D. 1, WILLOW STREET
717-464-3321



SUPPLY CENTER

1027 DILLERVILLE ROAD, LANCASTER
24 HOUR SERVICE DAILY PH: 717-397-4761