

From Local Ag Teachers:

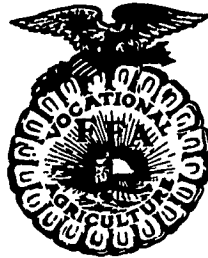

Thoughts in Passing



The article this week was prepared by Donald Robinson, Young Farmer advisor in the Eastern Lancaster County School District.

OUTDOOR RECREATION ENTERPRISES

As the weather changes from Winter to Spring the farmers thoughts turn to working his fields, but for millions of Americans, thoughts turn to planning vacations or having an enjoyable drive in the country.

What do these two thoughts have in common? - faamers may have what vacationers want-but neither knows it Have you ever considered developing a vacation farm, youth camp, golf course, swimming facility, picnicking and sports area, camping area, nature trail, riding, fishing and hunting facility, winter sports area, or some other recreational facility? Before you say it couldn't be done on your farm, read on

This short article cannot provide all the information you need to develop a recreational facility but it can provide some thoughts for you to analyze the possibilities

Three ingredients are necessary to any successful outdoor recreation enterprise resources, management, and location Resources are those areas that have natural or developed facilities that will bring enjoyment or relaxation to people Income producing recreation opportunities may crop up in the most unexpected places. For example, one farmer was about to tear down an old smoke house and spring house, instead he decided to restore them as a tourist attraction and



Donald Robinson

charge admission to come in and look them over It happened to be near a main highway so it developed into a thriving recreation business.

Another farmer put up a sign "\$1 to see the cows milked" and soon found he had to buy more cows to fill the demand (Continuous milking isn't the best way to develop a milk cow, of course, but the viewing may bring better returns than the milk).

The point is that not all recreational resources need to be spectacular "Beauty is in the eye of the beholder" they say So also it might be said, "Recreation opportunity is in the eye of the imaginative developer"—within limits. Which brings us to the next factor

Management covers many items such as aptitude, imagination, financing, and labor It is the proper blend of many ingredients. Aptitude is possibly the most important single component of any recreational enterprise. To be

successful in recreation one must like people in general well enough to put up with their foibles, moods, and sometimes annoying habits. He must look after their comfort He must, in short, keep his customer's interest up-permost in his plans at all times.

A person with imagination can make up for deficiencies in natural resources. One commonly thinks water and trees or both are necessary for a successful recreation enterprise, but think of the example of the smoke house. Every farmer and farmer's wife has a limitless store of interesting and entertaining information that can be the delight and an education to people brought up in the city.

Financing. A few people have founded successful recreational businesses on a shoestring, but more have failed. In this field, even more than in farming, it is necessary to have good arrangements for adequate financing.

Labor. A farm family adding a recreation enterprise to its agricultural operations often tends to overlook the amount of

time and energy that must be allocated to the recreation portion. Many times the individual entrepreneur is in a situation where service is the most important product he has to sell because service may not be available in a public facility nearby. In respect to labor, recreation may be an answer to the problem of under-employment brought about by a farmer's inability to acquire sufficient land to bring his unit up to adequate size from a labor utilization standpoint.

Location is always of importance in an industry such as recreation. Since we are already in a high tourist attraction area, this should be beneficial to a recreation type of enterprise, and would not need to be developed as much as in other areas. But as

stated in the beginning, you have what vacationers want. If you want to take advantage of that you need to develop your facilities to harvest that particular crop and let them know that you have it available.

Ham Insurance

A large canned ham in the refrigerator is especially valuable company dinner insurance in the summer when parties are often spontaneous and relatives or friends may drop in unexpectedly. A ham can be kept unopened in the refrigerator for several months. What if company doesn't materialize? No problem — that ham will make a fine family meal with leftovers for satisfying salads and hearty sandwiches.

More farmers each month prefer to buy their

- EAR CORN
- HAY ● STRAW

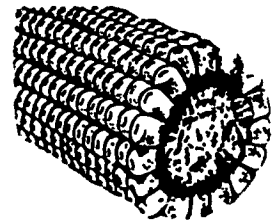

from us for better value and all around satisfaction. At farm or delivered, any quantity as your requirements may be.

Area Code 717 687-7631

ESBENSHADE TURKEY FARM

"America's Oldest"

PARADISE, PA.

AGWAY

STA-RITE Can Put A Pipeline In Any Barn

WHY BUY A PIPELINE?

For An Average 40 Cow Herd

You Can . . .

1. Save walking 100 miles a year.
2. Save carrying 292 tons of milk a year.
3. Save 200 hours per year on an average herd.
4. Produce higher quality milk.
5. Increase your milk production.

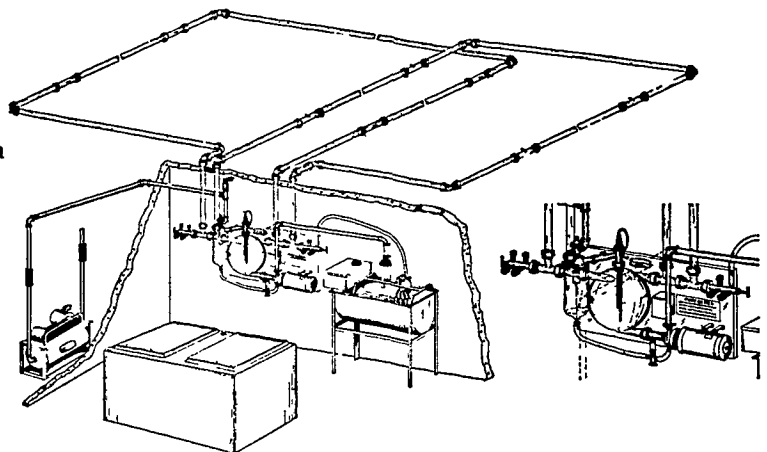

WHY BUY A STA-RITE PIPELINE?

1. Engineered for the modern dairy farm of today as well as the dairy farm of tomorrow. Around the barn pipelines and milking parlors.
2. The only milkhouse control unit that is assembled at our modern new factory on a stainless steel panel. Pretested for trouble free operation, self-draining with patented washing features.
3. Built and guaranteed by Sta-Rite Industries, Inc., of Delavan, Wisconsin, a recognized leader in home water systems and agricultural components.

- 24 Hour Milking Equipment Service
- Installation and Service

CALL TODAY AND ASK FOR AN APPOINTMENT

SUPPLY CENTER

1027 Dillerville Road, Lancaster



24 Hour Service Daily

Ph: 717-397-4761

CONTROL BOTH KINDS OF ROOTWORMS!



BUX® is one rootworm insecticide that combines proven effectiveness with an exceptionally low risk factor. It controls both resistant and non-resistant rootworms. And there's no miserable odor to smell up everything. Ask us about the many other reasons to choose BUX.

P. L. ROHRER & BRO., INC.

Smoketown, Pa.

Ph. 397-3539