

Safety Rules Explained for Employers

Hazardous Occupation Order for Farm Youths

Sixteen occupations are declared particularly hazardous for persons under 16 and are, therefore, prohibited to them according to the Hazardous Occupations Order issued by Secretary of Labor Willard Wertz

Exception — This subpart shall not prohibit the employment of a child below the age of 16 by his parent or by a person standing in the place of his parent on a farm owned or operated by such parent or person

Student-Learners — The findings in this subpart shall not apply to persons employed as vocational agriculture student-learners when all of the following requirements are met:

(1) The student-learner is enrolled in a course of study and training in a cooperative vocational education training program in agriculture under a recognized State or local educational authority or in a course of study in a substantially similar program conducted by a private school and:

(2) Such student-learner is employed under a written agreement which provides:

(a) That the work of the student-learner in the occupations declared particularly hazardous shall be incidental to his training

(b) That such work shall be intermittent and for short periods of time, and under the direct and close supervision of a qualified and experienced person

(c) That safety instructions shall be given by the school and correlated by the em-

ployer with on-the-job training and:

(d) That schedule of organized and progressive work processes to be performed on the job shall have been prepared.

Each such written agreement shall contain the name of the student-learner, and shall be signed by the employer and a person authorized to represent the school. Copies of each agreement shall be kept on file by both the school and the employer. This exemption for the employment of student-learners may be revoked in any individual situation where it is found that reasonable precautions have not been observed for the safety of minors employed thereunder.

Hazardous Occupations Defined
The 16 hazardous occupations recognized are:

1. Handling or applying anhydrous ammonia, organic arsenic herbicides, halogenated hydrocarbon pesticides, or heavy-metal fungicides, including cleaning or decontaminating equipment used in application or mixing of such chemicals.

Of the many agricultural chemicals used on farms, only those presenting serious health hazards are prohibited. Anhydrous ammonia has a corrosive effect on body tissues. The pesticides prohibited either affect the central nervous system, causing respiratory failure, or may cause death by the accumulation of even minute quantities over a prolonged period

Persons under 16 may still

handle and apply other types of fertilizers and less toxic agricultural chemicals.

2. Handling or using a blasting agent. The term "blasting agent" shall include explosives such as, but not limited to, dynamite, black powder, sensitized ammonium nitrate, blasting caps, and primer cord.

The use of blasting agents requires experience and expertise. Mishandling can result in accidental detonation, and maiming or loss of life.

3. Serving as flagman for aircraft.

The job of flagman for aircraft is hazardous because the flagman stands in the line of flight to direct the pilot and also because of the possibility of contamination from the chemical being applied.

4. Working as — a. Driver of a truck or automobile on a public road or highway; b. Driver of a bus.

Exposure to other traffic while moving at considerable speed makes driving a motor vehicle on a public road or highway hazardous. The additional responsibility of carrying passengers makes driving a bus unsuitable for youth under 16. They may still drive a truck or

automobile on the farm itself.

5. Operating, driving, or riding on a tractor (track or wheel) over 20 belt horsepower, or attaching or detaching an implement or power take-off unit to or from such tractor while the motor is

running.

Farm tractors can overturn and the operator or passenger may be seriously injured. Injuries are complicated if the accident occurs in an isolated

(Continued On Page 21)

GO WITH THE WINNER GO TROJAN

The Winner of the National
25 Acre Corn Growing Contest
(non-irrigated)

Trojan TXS 118 Yielded 237.98 bu. per acre.

America's Fastest Growing Seed Corn Company.

EUGENE HOOVER

LITITZ, R. D. 3
569-0756

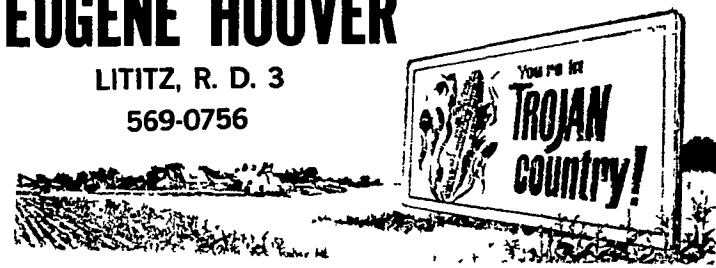

AGWAY

STA-RITE Can Put A Pipeline In Any Barn WHY BUY A PIPELINE?

For An Average
40 Cow Herd

You Can . . .

1. Save walking 100 miles a year.
2. Save carrying 292 tons of milk a year.
3. Save 200 hours per year on an average herd.
4. Produce higher quality milk.
5. Increase your milk production.

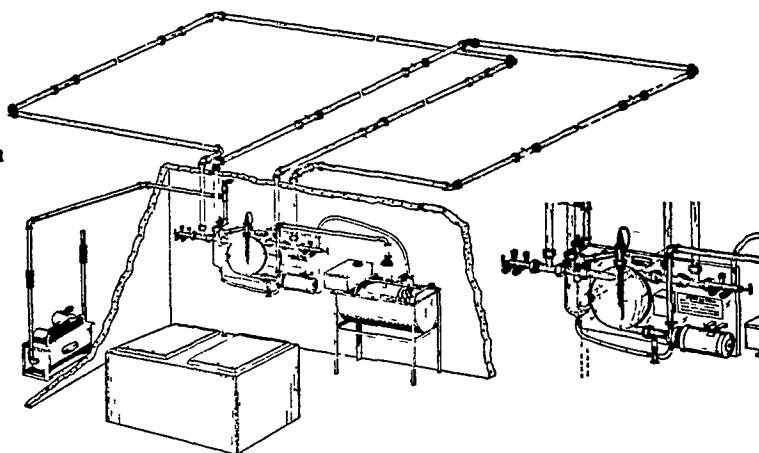

WHY BUY A STA-RITE PIPELINE?

1. Engineered for the modern dairy farm of today as well as the dairy farm of tomorrow. Around the barn pipelines and milking parlors.
2. The only milkhouse control unit that is assembled at our modern new factory on a stainless steel panel. Pretested for trouble free operation, self-draining with patented washing features.
3. Built and guaranteed by Sta-Rite Industries, Inc., of Delavan, Wisconsin, a recognized leader in home water systems and agricultural components.

- 24 Hour Milking Equipment Service
- Installation and Service

CALL TODAY AND ASK FOR AN APPOINTMENT



SUPPLY CENTER

1027 Dillerville Road, Lancaster

24 Hour Service Daily

Ph: 717-397-4761

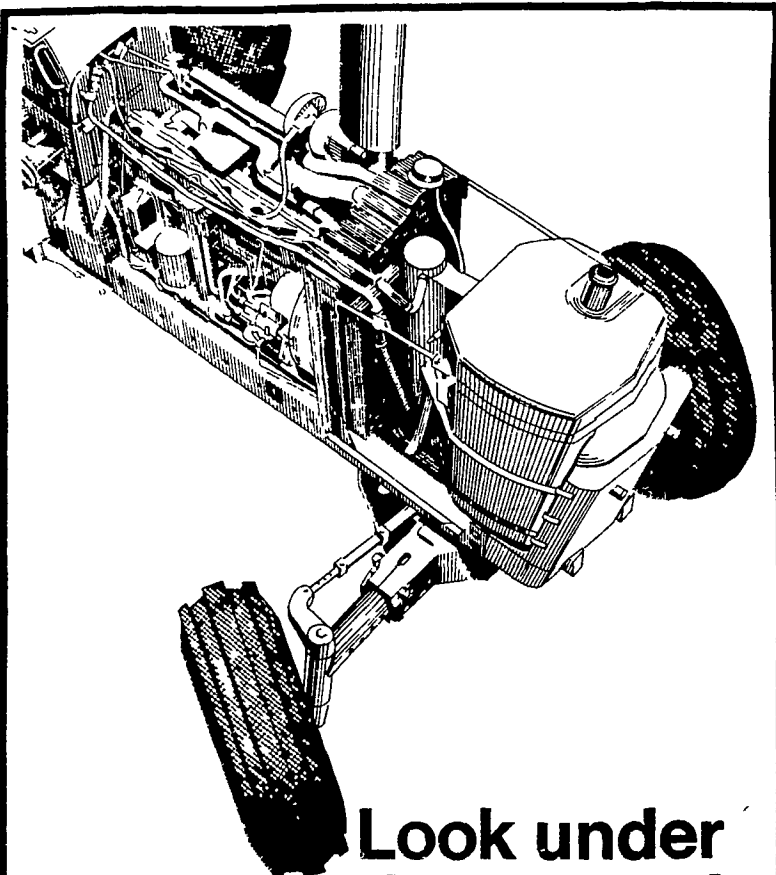

Look under the sheet metal

Don't let sheet-metal styling
blind you to the 14-cylinder power
of a John Deere Tractor

Eight pistons in the hydraulic pump, six in the engine. They team up to deliver control power that can be described as "electrifying," because John Deere's closed-center hydraulic system works like an electrical circuit — it uses engine power only when you turn on a hydraulic function. Compare this to competitive systems that are always "on," using power to constantly pump oil. Stop by and look into a dependable John Deere for yourself.



A. B. C. Groff, Inc.
New Holland 354-4191

Shotzberger's
Elm 665-2141

M. S. Yearsley & Sons
West Chester 696-2960

Landis Bros. Inc.
Lancaster 393-3906