

Pennfield Corp. Announces Egg Division Changes

Donald E. Horn, General Manager of Pennfield Corporation's Egg Division, announces three key managerial appointments effective immediately.

Glenn H. Herr has been named Production Manager for the entire Egg Division. In his position, he will be responsible for the three company-owned egg producing farms as well as the contract farms. Prior to his promotion to the Egg Division, Herr was associated with the company's Feed Division.

Ray W. Sheaffer, Sr. will be Processing Manager, responsible for operating the company's two packing plants as well as for egg deliveries to customers and the trucking of eggs from producing flocks to the Ephrata Plant. He will also concentrate on developing marketing and processing services for independent egg producers who are customers of Pennfield's Feed Division. Ray Sheaffer was the owner of L. M. Sheaffer Company, prior to its acquisition by Pennfield Corporation. He and his family reside in Ephrata.

William M. Nies, formerly of

the Accounting Department of Pennfield Corporation has been named, by Horn, as the Controller of Pennfield's Egg Division. He will be responsible for formulating divisional financial policies and procedures in keeping with the corporation's policies as well as interpreting, evaluating and appraising the Division's financial and accounting procedures for management. Nies and his family reside in Lancaster.

"These three key changes," said Horn, "are part of Pennfield's overall consolidation program." Pennfield Corporation was established in March, 1971 with the merger of Miller & Bushong of Lancaster and D. E. Horn & Co. of York. All three positions will report to Donald E. Horn.

Guernseys Average \$712. At Local Sale

50 purebred Guernseys, all ages, owned by Raymond Goeringer, Lake Louise Farm, Dallas, Pa., were sold at the Pa. Guernsey Breeders' Ass'n. Sales Pavilion February 3, for an average of \$712.

Goeringer, one of the top dairymen in the country, classified, showed, and made good records.

The top animal brought \$3,000 and was purchased by Edward C. Anderson, Richmond, Va. Her four month old calf brought \$1250, purchased by G.S. and Earl F. Colopy, Danville, Ohio.

The second high in the sale was a nine month old heifer calf by Western Glow Darimost, which sold for \$2,000 to Arnold Colopy, Danville, Ohio.

Eight head sold for over \$1,000. While most of the cattle stayed in Penna some went to Connecticut, Illinois, Indiana, New Jersey, Ohio, and Virginia.

Local buyers were Harry W. Blessing, Wrightsville; Harold Good, Airville; Douglas Kilgore, Airville; Rutter Bros., York; Mervin Myers, Littlestown, and James C. Weicksel, Christiana.

The sale was managed by The Merryman Co., Sparks, Md. and the Pa. Guernsey Breeders' Ass'n., Camp Hill.



Floyd and Barry Ott
Bangor, Pa.

"The Harvestore System solved our number one problem—labor. Last year we baled 10,000 bales, this year only 800 . . .

Just two of us can put up haylage. According to Pennsylvania Farmer's Association figures, purchased feed used to cost up \$1.00 per cwt. of milk. We have cut it down to 9¢ per cwt. Our cows came up .3% butterfat on high moisture corn. In '69, without Harvestores, our return on investment was 8.38%. In '70, with Harvestores, it was 13.42%."

PENN-JERSEY HARVESTORE SYSTEMS, INC.

New Holland, Pa.
Phone (717) 354-5171
1971 HARVESTORE DEALER OF THE YEAR

AGWAY

STA-RITE Can Put A Pipeline In Any Barn WHY BUY A PIPELINE?

For An Average
40 Cow Herd

You Can . . .

1. Save walking 100 miles a year.
2. Save carrying 292 tons of milk a year.
3. Save 200 hours per year on an average herd.
4. Produce higher quality milk.
5. Increase your milk production.

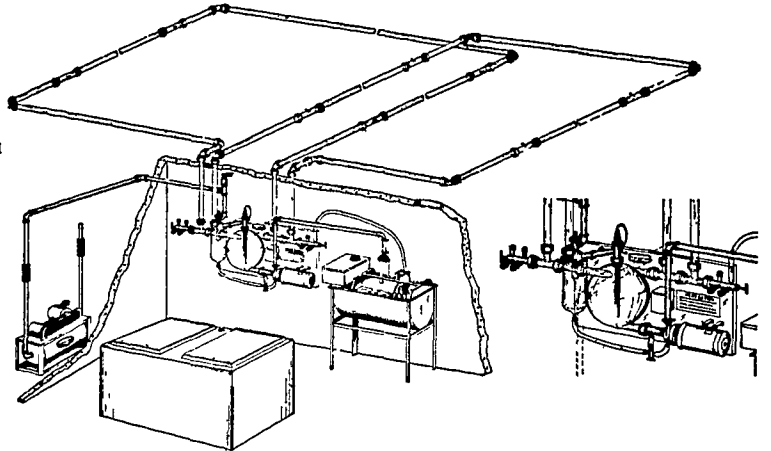

WHY BUY A STA-RITE PIPELINE?

1. Engineered for the modern dairy farm of today as well as the dairy farm of tomorrow. Around the barn pipelines and milking parlors.
2. The only milkhouse control unit that is assembled at our modern new factory on a stainless steel panel. Pretested for trouble free operation, self-draining with patented washing features.
3. Built and guaranteed by Sta-Rite Industries, Inc., of Delavan, Wisconsin, a recognized leader in home water systems and agricultural components.

- 24 Hour Milking Equipment Service
- Installation and Service

CALL TODAY AND ASK FOR AN APPOINTMENT



SUPPLY CENTER

1027 Dillerville Road, Lancaster

24 Hour Service Daily

Ph: 717-397-4761

Purina Dairy Conditioner Special can prepare cows for good production at low cost



If you're not among the many good local dairymen who have started mixing Purina Dairy Conditioner Special with your own grain to build a research-proved dry cow ration, it can pay you to check into this low-cost way of feeding dry cows.

Purina Dairy Conditioner is a 16 percent protein ration, fortified with extra Vitamins A and D plus phosphorus to help guard against milk fever.

To help you save on dry cow feeding, Purina Research recommends varying feeding levels, depending on cow condition and the quality of your roughages. For example, if a cow is in good condition and your roughages are of excellent quality, you would feed less Purina dry cow ration than if the cow were in only fair condition and if the roughages were of only fair quality.

*Reg. Trademark—Ralston Purina Co.

Using Purina Check-R-Mix* formulas we can build you a low-cost dry cow ration, combining Purina Dairy Conditioner with your grain. Or, if you're feeding low-protein roughages, it may pay you to feed Dairy Conditioner "straight" — just as it comes from the bag.

More and more successful area dairymen are proving that good dry cow feeding pays off in extra cow condition — and extra milk production in the next lactation. For example, 100 to 200 pounds of additional body weight at freshening can pay off in 1,000 to 2,000 pounds of extra milk during the lactation.

Drop in soon and get your free copy of the Purina Dry Cow Program folder. We'll be glad to point out how Purina Dairy Conditioner Special can help prepare your dry cows for good production at low cost.

John J. Hess, II, Inc.
Ph: 442-4632
Paradise

John B. Kurtz
Ph: 354-9251
R. D. 3, Ephrata

James High & Sons
Ph: 354-0301
Gordonville

West Willow Farmers Assn., Inc.
Ph: 464-3431
West Willow

Ira B. Landis
Ph: 394-7912
1912 Creek Hill Rd., Lane

Wenger's Feed Mill Inc.
Ph: 367-1195
Rheems

