

Sale Register

SAT. NOV. 9—9:30 A.M.—Complete Sellout Public Sale of Farm, Dairy Cattle, Equipment and some household goods, along Rt. 241, 5 mi. W of Elizabethtown, 1 mi. E of 441, Conoy Twp. Terms by Mrs. Willis (Bill) Shoemaker.

Sale Register

SAT. NOV. 9—11:00 A.M. Dairy Cattle Dispersal for Wm. Frederick, Sugarloaf, Pa.

TUES. NOV. 12—7 P.M. 2nd Tri-State Calf Sale at Abingdon Livestock Market, Inc., Abingdon, Va.

Sale Register

TUES. NOV. 12-2 P.M. Public Sale of Valuable Real Estate located 6 mi. W of Lancaster along Rt. 340 between Mountville Borough and St. Joseph's Convent Home, West Hempfield Twp., terms by Mr. and Mrs. Walter E. Booher.

Sale Register

WED. NOV. 13—10 A.M. Public Sale of Tractors and Farm Machinery at Wenger's Farm Machinery, Inc., So. Race St., Myerstown, Pa.

THURS. NOV. 14—12:30 Noon. Purebred Guernsey Sale at the Ass'n Sales Pavilion, Lancaster, Pa.

FRI. NOV. 15 — 1:00 P.M. Special Fall Feeder Auction, Lancaster Union Stock Yards, Sales Pavilion.

FRI. NOV. 15—8 P.M. Public Sale at Black & White Holstein Farm Dairy Cow Sale Pavilion along Rt. 230 Bypass directly across from the Comet Outdoor Theatre, just west of Lancaster.

FRI. NOV. 15—Public Auction of Top Grade Holstein Dairy Cattle to be held in the new Dairy Barn Pavilion at the Aberdeen Sale Co. in Churchville, Harford County, Maryland, located on Md. Rte. #22 — 6 miles East of Bel Air and 6 miles West of Aberdeen, Md.

Sale Register

SAT. NOV. 16 — 11:00 A.M. Public Sale of Valuable Farm Machinery, Tools and Household Goods, located 2 miles N. of Lititz, just E. of Brunnerville, along Pine Hill Road. Terms by P. Elmer Huber.

FRI. NOV. 22—12:45 P.M. Sharp Registered Holstein Sale located 6 mi. S. of Lancaster along Route 222 on the farm of Carl Diller, Lancaster County, Penna. Terms by Carl Diller and John J. Stoltzfus.

FRI. NOV. 22—7:00 P.M. Vintage Fall Feeder Sale at Vintage Sales Stables, Inc., 10 mi. E. of Lancaster on Rte. 30.

SAT. NOV. 23 — 11:00 A.M. Large Real Estate Sale, Two Farms containing 393 acres. Located on Airville R. D. #2, along Rt. 425 in the Village of Woodbine, Fawn Township, York County, Pa. Terms by Mr. & Mrs. Dale A. Torbert, Airville, Pa., R.D.2, Owner.

SAT. DEC. 14—10:00 A.M. Public Sale of New and Used Tractors, Farm Machinery, Lawn & Garden Equipment, tools and miscellaneous. Terms by Miller Feed and Implement Co., Highway 851, Stewartstown Pa.

SAT. MAR. 1—Another All Day Community - Farm Sale at Georgetown on Rt. 896, 6 mi. SE of Strasburg. Sponsored by Bart Twp. Fire Co. (Watch for large ad.)

ATTENTION FARMERS...

WHY SHOULD YOU BUY A NEW CASE FARM TRACTOR NOW?

1. **25%** discount on any New Case tractor on our lot purchased during November.
2. Waiver of Finance Charges until spring.
3. 7% tax investment credit.
4. 20% depreciation allowance on 1968 tax return.
5. Protection from company price increases.

STOP IN TODAY FOR ANY EQUIPMENT NEEDS.

KINZER EQUIPMENT CO.

Box 23, Kinzers, Pa.

Phone 442-4186

Robert K. Rohrer

**Bulldozing - Grading
Patz Sales & Service**

**Barn Cleaners - Silo
Unloaders - Cattle Feeders**

Quarryville, R. D. 1
Hensel 548-2559



2275 OLD PHILA. PIKE
LANCASTER, PA.
PHONE 397-4829

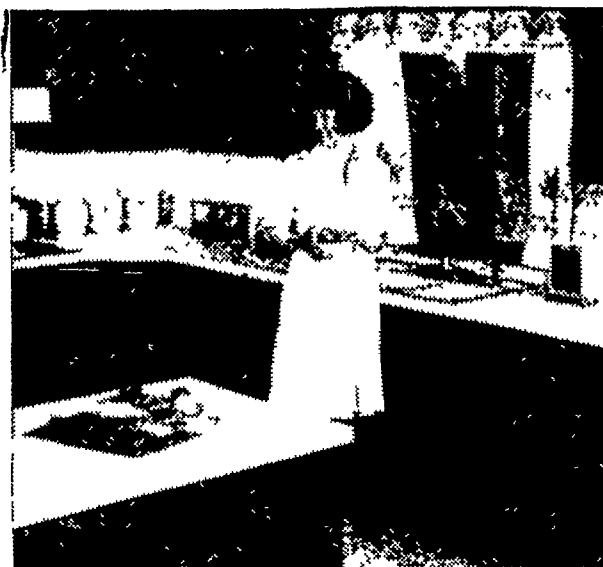

PRESTIGE KITCHEN CABINETS

By Weather-Seal, Inc.

Ten Foot Section With Preformed Counter Top . . . **\$252.21** Plus Tax

Feet —	1	2	3	4	5	6	7	8	9	10
1	W4230 Wall 42"		Valance				W4230 Wall 42"			
2	Contemporary Style									
3	18"	24"	36"				24"	18"		
4	Drawer D-18	Base B-24	SFRF-36 Sink				Drawer D-24	Base B-18		

Quan.	Stock Number	Amount	Total
2	W4230	33.78	67.57
1	4' Valance	5.39	5.39
1	D-18	33.15	33.15
1	B-24	29.87	29.87
1	D-24	36.86	36.86
1	B-18	24.72	24.72
1	SFRF-36	19.65	19.65
1	10' Preformed Top	35.00	35.00
Total		252.21	252.21

Plus Tax

**WE STOCK
AMEROCK
CABINET
HARDWARE**

Preformed Counter Tops

Each	Price
4'	14.00
5'	17.50
6'	21.00
8'	28.00
10'	35.00
12'	42.00

Railite®

DECORATOR - APPROVED
PLASTIC LAMINATE SHEETS

Low Cost
Easy to Install

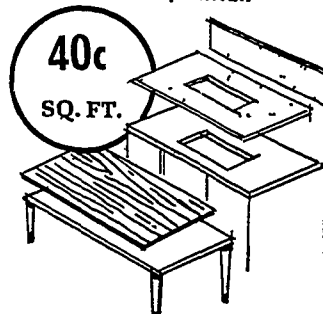

NOW—from SIEGLER SUPER FLOOR HEAT!

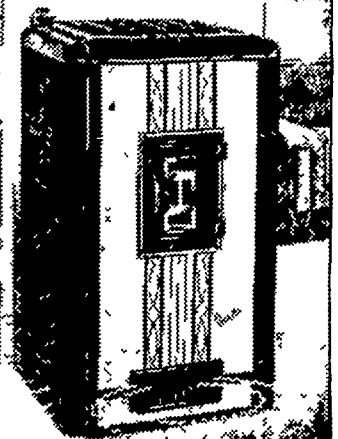

You get **4-TIMES MORE** HEAT OVER YOUR FLOORS than ever before!

PATENTED
Siegler
AUTOMATIC FORCED AIR
OIL HOME HEATER

It pays for itself with the fuel it saves!
SEE IT SOON AT

L. H. Brubaker

350 Strasburg Pike, Lancaster R.D. 3, Lititz, Pa.

Phone Lancaster 397-5179
Strasburg 687-6002
Lititz 626-7766