

DHIA MONTHLY REPORT

(Continued from Page 13)

Owner - Name	Breed	Age	Days	Milk	Test	Fat
J. Rohrer Witmer Gay	RBrSw	4-9	305	14,113	4.8	677
J. Z. Nolt Royal	RH	2-7	305	16,856	4.0	675

HIGH MONTHLY DAILY AVERAGES OF BUTTERFAT

Owner	Breed	Days On Test	No. Cows	% Cow Days In Milk	Milk Lbs.	% Fat	Fat Lbs.
Stanley G. Greiner	RH	32	23.0	95.1	53.8	3.8	2.02
Lloyd Wolf	R&GrH	34	41.8	92.6	51.1	3.9	1.99
Dr. Paul S. Schantz	Mix	32	17.0	100.2	45.7	4.1	1.88
Hiram S. Aungst	RH	31	32.9	92.2	49.7	3.7	1.86
Amos M. Stoltzfus	RH	32	26.4	90.2	50.1	3.5	1.76
Titus B. Stoner	R&GrH	29	29.8	94.7	49.3	3.5	1.74
C. Richard Landis	RH	31	35.6	99.8	48.1	3.6	1.72
John L. Landis	R&GrH	32	39.0	95.6	48.1	3.6	1.71
Donald S. Eby	RH	35	44.7	87.6	43.3	3.9	1.71
Samuel S. Stoltzfus	RH	34	28.3	92.4	46.4	3.7	1.71
Red Rose Research Center	RH	32	27.0	93.1	47.0	3.6	1.70
Samuel S. Stoltzfus	RH	27	28.0	92.9	44.8	3.8	1.69
W. Kenneth Hershey	R&GrH	34	37.3	93.0	48.2	3.5	1.68
W. Harold Musser & Son	R&GrH	34	37.5	95.3	46.8	3.6	1.67
Robert L. Fahnestock	RH	27	16.0	97.2	48.8	3.4	1.66

I may never save a dollar in my life, but I am benefited by every dollar saved by others which is put to productive use.

Meal Planning
Regular planning gives you an opportunity to serve meals that have flavor interest, variety in color, and texture contrast, reminds Louise Hamilton, Penn State extension foods and nutrition specialist. When planning menus, consider the dinner meats first, then build around the main dish for lunch. Fit in the dinner and luncheon vegetables and salads. Next plan the week's breakfasts and then decide on luncheon and dinner desserts.

When everything else fails try reading the directions.

Robert K. Rohrer

**Bulldozing - Grading
Patz Sales & Service**

**Barn Cleaners - Silo
Unloaders - Cattle Feeders**

**Quarryville, R. D. 1
Hensel 548-2559**



Now...

**MECHANIZE YOUR
STANCHION BARN
FEEDING WITH
THE NEW**

**SELF-PROPELLED
BUNK FEEDER**

Save time... save labor... take the hand work out of feeding in your barn. This feeder will evenly distribute silage, chopped hay, grain or supplements the entire length of your barn. It can be installed in barns with cows facing in or out. Lengths up to 225 ft. For all the details, call or write.

Grumelli Farm Service
Quarryville

Isaac W. Hurst
Blue Ball

R. M. Brubaker & Son
Salunga

Carl L. Shirk
Colebrook Rd., Fontana

NEPPCO Official Calls For Unity, Leadership In The Coming Year

Strong leadership in dealing with the common problems of the poultry industry should be the primary goal for the year ahead, according to Richard I. Ammon, executive director of the Northeastern Poultry Producers Council (NEPPCO).

In a brief address to the annual meeting of the Council, held at a "Booster Breakfast" in the Penn Harris Hotel here last week, Ammon pointed out that "the industry has a golden opportunity to develop constructive solutions to some of its knottiest problems — develop practical common goals — and unite behind them."

He told his audience that the Council's primary objective in the year ahead should be to provide the leadership that will bring together divergent industry views for a united program of progress. The executive director pointed out that NEPPCO's attempt to develop this unity in the form of a National Egg Congress last year had not been successful, with the result that the industry presented a "splintered" image in seeking legislative objectives.

In other action taken at the meeting, six NEPPCO directors were elected, each to represent his respective state in the year ahead. They were Leon F. Lord, Fairfield, Me.; Hiram H. Frank, North Branch, N.Y.; Edwin J. Carev, Marion, Ohio; Russell C.

Latshaw, Barto, Pa.; Reino W. Tikkanen, Foster, R.I., and David L. Shetzlich, Baltimore, Md. Officers for the coming year will be chosen at the board of directors' first meeting.

Recognized at the breakfast

were members of the NEPPCO Thunderbird Club. This is an elite group that earns its "membership" by investing \$100 or more in the Council each year. At present its roster includes 31 individuals and companies.

Everyone has a choice. He can either change his ways or endure the results.

"YIELD-PROVEN" Superiority

Plant PIONEER "New Generation" Hybrids

Medium Season

3567 — 3570
3466 — 3561

Full Season

3306 — 3304
3369A — 323

Ask your Pioneer Salesman
about these Outstanding Varieties



PIONEER
BRAND
SEED CORN

Perfection Can Put A Pipeline In Any Barn

WHY BUY A PIPELINE?

For An Average
40 Cow Herd
You Can . . .

1. Save walking 100 miles a year.
2. Save carrying 292 tons of milk a year.
3. Save 200 hours per year on an average herd.
4. Produce higher quality milk.
5. Increase your milk production.

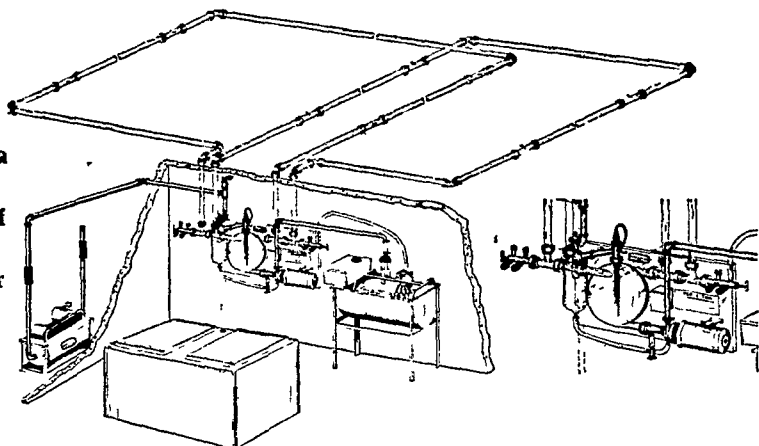

WHY BUY A PERFECTION PIPELINE?

1. Engineered for the modern dairy farm of today as well as the dairy farm of tomorrow. Around the barn pipelines and milking parlors.
2. The only milkhouse control unit that is assembled at our modern new factory on a stainless steel panel. Pretested for trouble free operation, self-draining with patented washing features.
3. Built and guaranteed by Perfection Milker-Division of Sta-Rite Industries, Inc., of Delavan, Wisconsin, a recognized leader in home water systems and agricultural components.

● 24 Hour Milking
Equipment Service

● Installation and Service

CALL TODAY AND ASK FOR AN APPOINTMENT

Agway Bee Line's Local Commodity Technicians are:
MR. FRED KERLIN — MR. HAROLD KINSEY



Bee Line Supply Center

1027 DILLERVILLE ROAD, LANCASTER

24 HOUR SERVICE DAILY — PH. 717-397-4761